

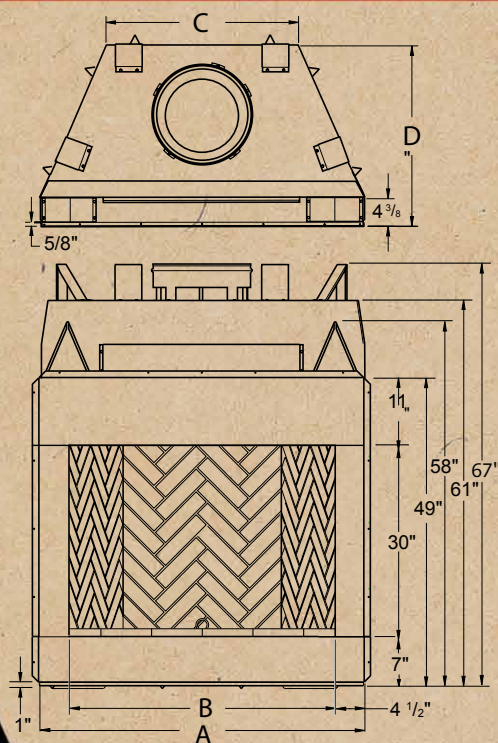

**Rapture Radiant Gas Fireplace Product Offering Summary**

<b>Available Accessories</b> <ul style="list-style-type: none"> <li>• Extruded Aluminum, Custom Anodized Bi-Fold Glass Door Systems (Ebony, Pewter &amp; Oiled Bronze)</li> <li>• Custom Fit, Precast Concrete Mantles</li> <li>• Certified Decorative Chase Covers</li> <li>• Masonry Wood Storage Nooks</li> <li>• Outside Combustion Air Kits</li> </ul>	<b>Fireplace Chassis:</b>	<ul style="list-style-type: none"> <li>• 36", 42" &amp; 50" Width Sizes</li> </ul>
	<b>Masonry Firebrick Wall Kits:</b>	<ul style="list-style-type: none"> <li>• All Sizes Feature Split Brick</li> <li>• Warm Red &amp; Ivory</li> <li>• Running Bond or Herringbone</li> </ul>
	<b>Burner &amp; Log Modules:</b>	<ul style="list-style-type: none"> <li>• 36", 42" &amp; 50" Sizes</li> <li>• Natural Gas or Propane</li> </ul>
	<b>Venting Options:</b>	<ul style="list-style-type: none"> <li>• Fmi 8" Double Wall Chimney</li> <li>• 8" Type "B" Venting</li> </ul>



BTU Sizing Chart			
	36"	42"	50"
NG	32 - 53,000	37 - 62,000	38 - 66,000
LP	39 - 52,000	43 - 59,000	46 - 63,000

	36"	42"	50"
A	45	51	59
B	36	42	50
C	29	30 1/2	38 1/2
D	26 5/8	28 1/2	28 1/2



Superior design, performance and features together with traditional wood-burning realism hallmark the most innovative, most advanced hearth products ever available. Only from Design Dynamics.



# INNOVATION ON FIRE

It isn't often that a product offers looks, features, performance and quality at a level to lead an entire industry in virtually every category. Design Dynamics™ introduces the new "Rapture" Radiant Gas Fireplace; a rare hybrid of modern innovation with an elegant and traditional masonry design.

## DRAMATIC BEAUTY

The first thought you may have of the Rapture is that it doesn't look like a gas fireplace. And if so then we've done a good job. We started with an enormous, wood-burning fireplace chassis featuring our patented firebrick lining system; indistinguishable from site-built masonry. Then we added a low profile, ceramic ember-ramp log set with lively, natural flame patterns and a deep smoldering glow. We hid all controls and gas lines beneath the hearth floor to maximize the woodburning look and feel. Then we topped it all off with a set of beautiful hand-forged andirons and a detailed hearth media kit.

## THE VERSA-FIRE™/ MOSAIC MASONRY™ SYSTEM

The Rapture features our new patent pending Mosaic Masonry™ firebrick walls. The traditional manufactured fireplace chassis is designed to accept a variety of kiln-fired clay firebrick walls. After the easy to install masonry wall system is fastened into place, the patented, fully unitized ember bed ramp burner and log module drop into the hearth floor. This feature also allows for the installation of future, technologically advanced, log and burner systems as they develop. It features a fully electronic ignition system with a 40% turn down capacity which can be operated by wall switch or included remote control. True hand-forged andirons and masonry chain-mesh pull screens complete the luxurious masonry design.



## INCOMPARABLE PERFORMANCE

Design Dynamics' patented, radiant heat technology is a clear departure from any other gas fireplace burner produced over the past 50 years. In fact it's the most realistic, convenient, and heat efficient gas log system made. It's designed to produce an intense red glow that not only creates uncanny wood burning realism, but also produces radiant heat with efficiencies comparable to most direct vent fireplaces, and clearly superior to any open-faced gas fireplace or conventional gas logs. The soot-free performance of the Rapture's burner system also rivals many vent-free heaters. Even in propane installations. For maximum flexibility, combustion air may be vented using either our 8" double wall chimney, or 8" B-type venting.

## QUALITY STANDARD FEATURES

- |  |   |
|--|---|
| 1. 30" tall opening in 36", 42" and 50" widths.  | finished right up to the opening.               |
| 2. Mosaic Masonry™ engineered firebrick walls are indistinguishable from site-built masonry. | 6. Functional Masonry Mesh Screen               |
| 3. Patented ceramic Ember Ramp technology burner.  | 7. Damper                                       |
| 4. Premier, Fully Unitized Log Stack   | 8. Hand-Forged Andirons                         |
| 5. Clean face masonry design can be  | 9. Concealed Electronic Ignition/Control System |
|  | 10. Full Length Nailing Flanges                 |
|  | 11. Remote Control                              |
|  | 12. Tough, Textured Powder Coat Finish          |

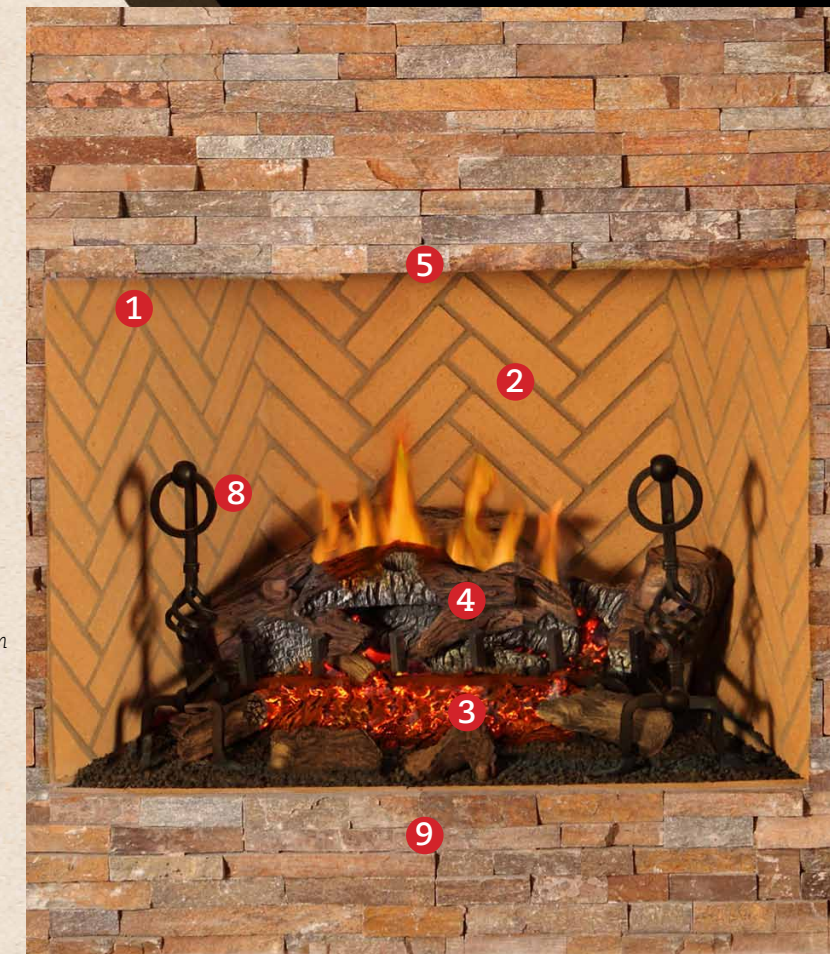

The Rapture's easy to install, patent pending Mosaic Masonry™ wall system features real, kiln-fired firebrick in 2 colors and 2 brick patterns



Incredibly detailed premium log stack is unitized to the burner as a single system. Patented ceramic Ember Ramp burner generates a realistic smoldering glow.

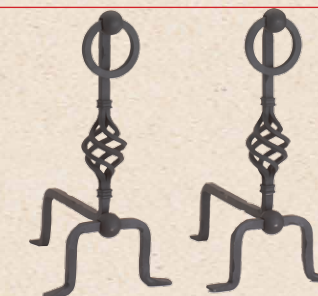

The Rapture features two true, Hand-Forged Andirons. Not some cheap, cast import.



Fully electronic ignition and gas controls are hidden for realism, and accessible through the front hearth brick.