

# Chateau

The Renaissance Series

36" AND 42" DIRECT VENT GAS FIREPLACES  
KC36 and KC42 Model Series

Ultimate Blend of  
Beauty, Features  
and Technology



*Stylish extras for homeowners...Better value for builders*

FIREPLACES  
FOR BUILDERS  
**Fmi**

# Timeless Beauty, Convenient Features — And The Latest Technologies

Fully loaded and truly impressive, Fmi's Chateau direct vent sets tough standards for any gas fireplace. The innovative **Chateau** captures all the latest visual and functional technologies, features and conveniences available. It's the flagship gas product of our exciting Renaissance Series, which features a variety of looks, with common sizing and construction across the entire product line... plus beautiful features homeowners will love!

## Homeowner Highlights:

- **Distinctive Realism**—Features exquisite “mature” fire presentation with colorful, random dancing flame patterns, massive ceramic fiber gas log set with deep glowing coals and embers.
- **Flexibility**—All Fmi Renaissance Series direct vent fireplaces are built on a common chassis and burner platform. The *VersaFire*® modular design allows the homeowner to upgrade the burner and log system at any time.
- **Choices**—Chateaus are available with attractive clean-faced screen, or premium rolled louvers with chain mesh pull screens. Millivolt and electronic ignition units are both available, as are natural gas and propane fuel options and your choice of refractory brick liners.
- **Massive Viewing Area**—Tall profile, captures the industry's largest glass door viewing area in both 36" and 42" size categories.
- **Operation and Maintenance are a Breeze**—Operates from wall switch or remote control. Hinged door swings open for easy maintenance and never needs adjustment.

## Builder Benefits:

- **Modular Design**—Fmi's unique *VersaFire*® platform allows the builder the opportunity to install fireplace chassis' in the framing stage, without having to set the burner and log system until finish. This minimizes job site loss or damage, with the flexibility of upgrading models right up to closing.
- **Simple, Secure, and Straight Installation**—Chateaus include fully unitized log sets for ease of installation, and they frame straight and sturdy every time with full-length drywall stopping nailing flanges.
- **Venting Options**—The Chateau's 45° slant back design lets you choose between horizontal and vertical venting of our 5" - 8" pipe for versatile, painless installation in any location.
- **More Standard Features**—Realistic, colored and textured refractory brick liner, premium rolled louvers, tough, powder coat finish, Flex gas connector with shut-off valve and pre-wired, dual access electrical “J” box are all standard.



www.fmiproducts.com  
For more information, call (866) 328-4537

FA6182 0810

The Renaissance Series

Chateau

36" AND 42" DIRECT VENT GAS FIREPLACES  
KC36 and KC42 Model Series



KC36N features natural gas and stacked design textured and colored brick-lined interior.



KCC42EPH is our 42" clean-faced propane model with textured herringbone brick liner and electronic ignition.

## Chateau Product Offering Summary

- Clean or Louver Faced Models
- 36" and 42" Viewing Area Widths
- Millivolt or Electronic Ignition
- Natural Gas or Propane Fuel
- Finished or Brick Refractory Lined Interiors (Color / Textured on 36" models)
- All Fireplaces use 5" - 8" Pipe
- Approved ANSI Z21.88



*Chateau models feature massive, mature wood fire presentation with gorgeous glowing ember bed burner with beautiful cast iron grate treatments and andirons.*



*Hinged tool-less entry glass door swings open for easy maintenance and never needs adjustment.*

Size	BTU(NG)	BTU(LP)
36"	23,000 - 33	22,000 - 31
42"	27,000 - 38	25,000 - 36

## Accessory Offering Summary

- Cabinet Mantels
- Designer Door Facings
- Multi-Function Remote Control Kits
- Decorative Filigree Circulating Panels in Black, Brass or Platinum
- Rolled Louver Trim (Brass & Platinum)
- Perimeter Trim Kits (Black, Brass & Platinum)
- Heat Circulating Fan Kits
- Heat Deflection Hoods
- Fuel Conversion Kits
- Standard or High Altitude Models Available

## Firebox Dimensions

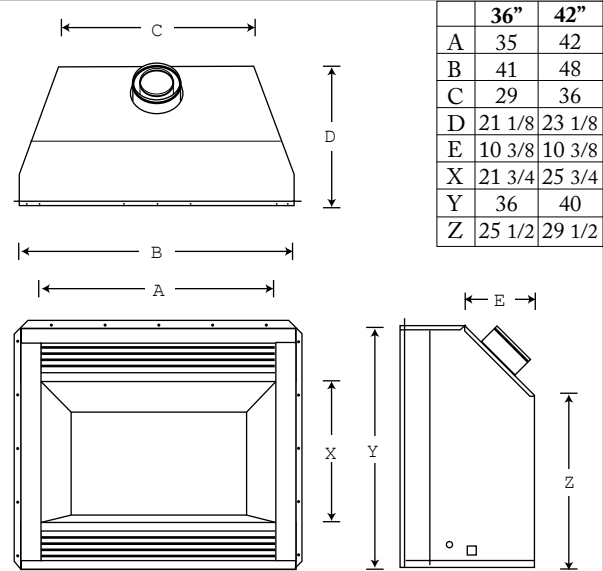

© 2010 FMI PRODUCTS, LLC



Tested & Certified



Printed in U.S.A.

Product design, features and specifications are subject to change at any time. Refer to current product instructions prior to installation.