

Vent Free Universal Masonry Firebox

Models MFP39/44/49VF

⚠ WARNING:

If the information in these instructions is not followed exactly, a fire or explosion may result causing property damage, personal injury or death.

Do not store or use gasoline or other flammable vapors and liquids in the vicinity of this or any other appliance.

WHAT TO DO IF YOU SMELL GAS:

- Do not try to light any appliance.
- Do not touch any electrical switch; do not use any phone in your building.
- Immediately call your gas supplier from a neighbor's phone and follow the gas supplier's instructions.
- If you cannot reach your gas supplier, call the fire department.

Installation and service must be performed by a qualified installer, service agency, or the gas supplier.

IMPORTANT: READ THESE INSTRUCTIONS CAREFULLY BEFORE STARTING INSTALLATION OF THIS FIREPLACE.

This firebox has been tested and approved by PFS under ANSI Z21.91 for use with any ANSI Z21.11.2 approved gas logs.

FOR USE ONLY WITH A LISTED GAS-FIRED UNVENTED DECORATIVE ROOM HEATER NOT TO EXCEED 40,000 BTU/HR

DO NOT BUILD A WOOD FIRE.

Carefully review the instructions supplied with the decorative type unvented room heater for the minimum fireplace size requirement.

DO NOT INSTALL AN APPLIANCE IN THIS FIREBOX UNLESS THIS FIREBOX MEETS THE MINIMUM DIMENSIONS REQUIRED FOR THE INSTALLATION.

Do not store gasoline or other flammable vapors and liquids in the vicinity of this or any other appliance.

Installer: Leave these instructions with the consumer.

Consumer: Retain for future reference.



We recommend that our gas hearth products be installed and serviced by professionals who are certified in the U.S. by the National Fireplace Institute® (NFI) as NFI Gas Specialists.

This appliance is only for use with the type of gas indicated on the rating plate. This appliance is not convertible for use with other gases, unless a certified kit is used.



Report No. 08-154



ICC Evaluation Services
Report No. 2401

CONTENTS

Fireplace Parts Diagram	Pg. 2
Fireplace Parts List	Pg. 3
General Information	Pg. 4
Safety Information	Pg. 5
Location.....	Pg. 6
Supporting Floor Systems.....	Pg. 6 ~ 7
Mason-Lite Weight Determinations	Pg. 8
Clearances	Pg. 9,10
Air for Combustion and Ventilation.....	Pg. 10,11
Important Pre-installation Information	Pg. 12
Fireplace Assembly Procedures.....	Pg. 13 ~ 15
Gas Piping Installation	Pg. 15
Electrical Line Feed.....	Pg. 15
Firebrick Liner Installation	Pg. 16
Initial Fireplace Operation	Pg. 16
Appendix I	Pg. 17
Appendix II	Pg. 18
Warranty Information.....	Pg. 19

Below is a sample picture of the rating plate that is located inside the lower dome side of your fireplace. Model Number, Date of Manufacture and Serial Number should be stamped on the plate where indicated.

 Masonry Fireplace Industries, LLC 315 West 3rd St., Santa Ana, CA 92701	FOR USE WITH LISTED ANSI Z21.91-2007 UNVENTED DECORATIVE ROOM HEATERS NOT TO EXCEED 40,000 BTU/HR (11.723W) CONSULT WITH INSTRUCTIONS FOR THIS FIREBOX FOR FURTHER INFORMATION.	
	MODEL No.:	DATE OF MFG:
<input type="checkbox"/> MFP39VF	<input type="checkbox"/> MFP44VF	<input type="checkbox"/> MFP49VF
THIS APPLIANCE NEEDS FRESH AIR FOR SAFE OPERATION AND MUST BE INSTALLED SO THERE ARE PROVISIONS FOR ADEQUATE COMBUSTION AND VENTILATION AIR.	SERIAL No.	BOTTOM <input type="text" value="0"/> " OPENING TO CEILING <input type="text" value="42"/> " TOP/BACK/SIDES <input type="text" value="0"/> " RECESS DEPTH <input type="text" value="18 1/2"/> "
Tested & Listed By Report No. 08-154	MANTEL CLEARANCES 0" - 10" : NO PROJECTIONS 16" - 22" : MAX. PROJ. 10" - 16" : 1-1/2" MAX. PROJ. 22" & ABOVE : 10" MAX. PROJ. 3" MIN. : 1-3/4" MAX. PROJ.	
ICC Evaluation Services Report No. 2401	DO NOT REMOVE THIS LABEL Refer to installation instructions and check local codes prior to installing. This appliance must be installed in accordance with local codes if any, if not, in accordance with the National Fuel Gas Code ANSI Z223.1 or CAN/CGA B.149 installation codes.	
ANSI Z21.91-2007 Ventless Firebox Enclosures for Gas-Fired Unvented Decorated Room Heaters.		

Fireplace Parts Diagram

Figure 1
Exploded Diagram

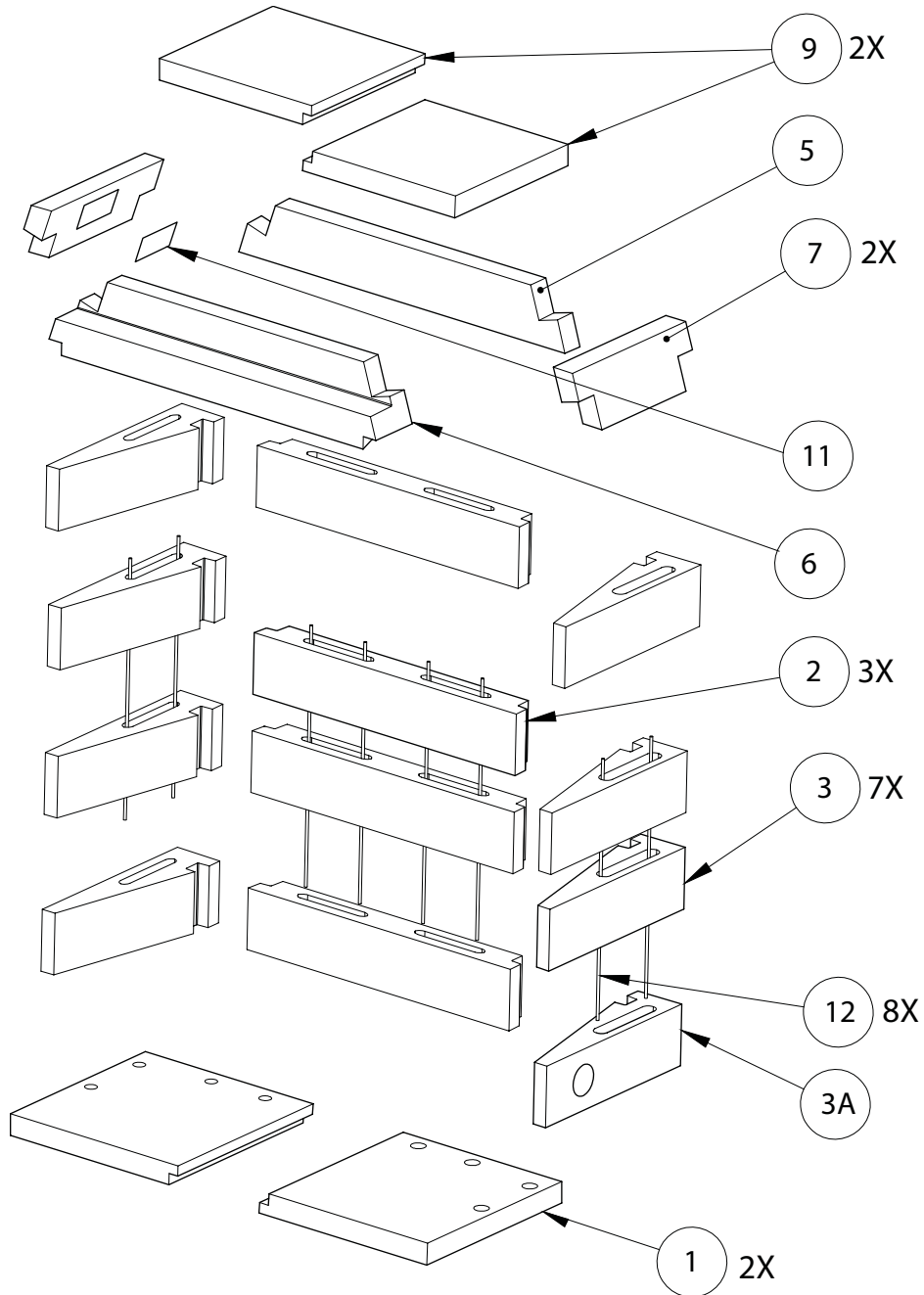

WARNING

Failure to position the parts in accordance with these diagrams or failure to use only parts specifically approved with this appliance may result in property damage or personal injury.

Customer Service & Parts Replacement

Parts and accessories may be purchased from your local dealer. Additional information is available from Masonry Fireplace Industries, LLC. Accessory orders will be accepted by mail, or you may call your order in at: (800)-345-7078.

MFP39/44/49VF Fireplace Parts List

ITEM	P/N	DESCRIPTION	QTY
1	MFP39-1 MFP44-1 MFP49-1	HEARTH (Left or Right)	2
2	MFP39-2 MFP44-2 MFP49-2	REAR WALL	4
3	MFP39-3 MFP44-3 MFP49-3	SIDE WALL	7
3A	MFP39-3A MFP44-3A MFP49-3A	SIDE WALL with 4" hole for Air Kit	1
5	MFP39-5 MFP44-5 MFP49-5	DOME REAR - LOWER	1
6	MFP39-6 MFP44-6 MFP49-6	LINTEL	1
7	MFP39-7 MFP44-7 MFP49-7	DOME SIDE - LOWER	2
9	MFP39-9 MFP44-9 MFP49-9	DOME TOP	1
11	MFP170	RATING PLATE	1
12		#3 REBAR (Ø3/8") x 36"	8

**Optional Outside Ø4"
Combustion Air Kit
Model No.: MFP4-AK**

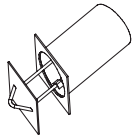

(Ø4" Ducting not included)

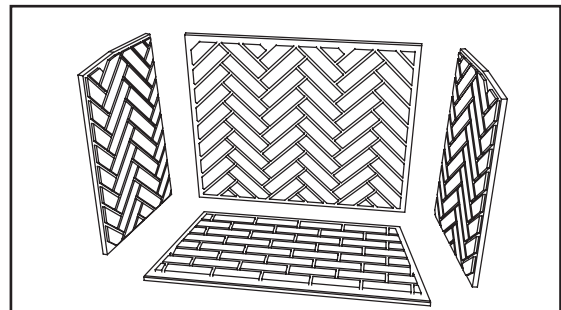

**MFP(39,44,49)SHBL- Herringbone
MFP(39,44,49)FRBL- Running Bond**

Refractory Firebrick Liners
(Herringbone Pattern shown, also available
in Running Bond - see Pg.16)

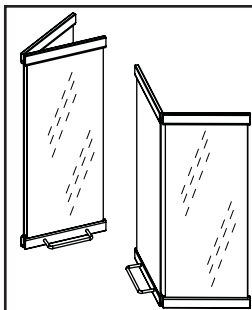

**Only the following
doors have been tested
and approved for use
with this fireplace:**

Crown-Breckinridge
or
McKenzie-Pendelton

General Information

Introduction

We extend a warm welcome from all of us at Masonry Fireplace Industries, LLC. (MFI), proud manufacturers of Mason-Lite Fireplaces.

Thank you for Choosing MFI.

You may have thought long and hard before you chose the fireplace which would grace your home. Rest assured that every component of the Fireplace has been tested to ensure long-term durability.

Before Beginning the Installation

Read these instructions carefully before beginning the installation of this Vent-Free fireplace. Also read the gas log appliance manufacturer's literature regarding sizing and suitability for installation into this Enclosure prior to installation.

Statement of Intended Use:

The Mason-Lite Vent-Free Universal Masonry Fireplace is a modular refractory masonry unit designed for field assembly. The firebox is constructed using pre-cast, interlocking refractory blocks. The blocks are then secured to each other using Mortar. The system includes all parts necessary for the assembly of a complete masonry vent-free decorative gas log enclosure.

In addition to the basic enclosure, a standard 1-1/8" thick, high temperature refractory brick is required to line the interior of the firebox.

These fireplaces are not intended to serve as a primary heat source, rather, the fireplace was expressly created as a supplemental source of heat.

The MASON-LITE is Designed for Use Only with any Vent free decorative gas log sets meeting standard ANSI Z21.11.2

Vent free decorative gas log sets meeting standard ANSI Z21.11.2, are supplied by others and are limited to any listed vent-free gas-fired log sets with heat input ratings up to 40,000 Btu/hr.

WARNING: Any application other than the "Intended Use" as stated above is in violation of the manufacturer's instructions and is hereby prohibited. Such violation may cause immediate hazard, property damage or loss of life and will void all liabilities to the manufacturer and will void all warranties explicit or implied.

Product Overview

Mason-Lite fireplaces are designed as Factory Built - Field Assembled Fireplaces to be installed on both combustible and non-combustible floor systems. They have been extensively tested to perform with excellent results in this environment.

Attention: Be advised that all the illustrations in this manual are for general reference only. They are not drawn to scale. Actual design elements will vary from case to case. Pay attention to specified minimum clearances as they relate to combustible materials.

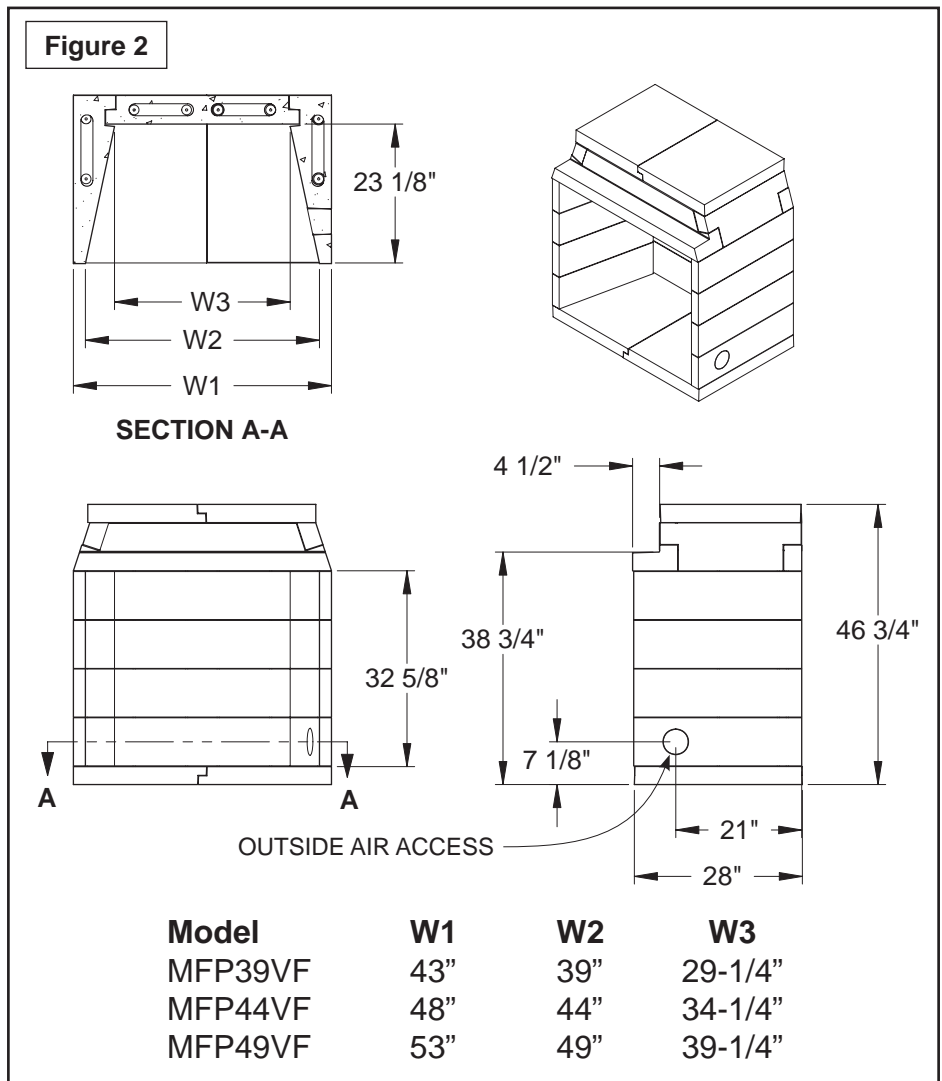

Safety Information

⚠ DANGER:

Carbon monoxide poisoning may lead to death!

Carbon Monoxide Poisoning: Early signs of carbon monoxide poisoning resemble the flu, with headaches, dizziness, or nausea. If you have these signs, the fireplace may not be working properly. **Get fresh air at once!** Have the fireplace serviced.

Note: Some people are affected more than others by carbon monoxide. These may include pregnant women, people with heart or lung disease, are anemic, anyone under the influence of alcohol, and those at high altitude.

IMPORTANT: Read this owners manual carefully and completely before trying to assemble, operate, or service this fireplace. Improper use of this fireplace can cause serious injury or death from burns, fire, explosion, electrical shock, and carbon monoxide poisoning.

General Safety Concerns

1. If you smell gas
 - Shut off gas supply.
 - Do not try to light any appliance.
 - Do not touch any electrical switch; do not use any phone in your building.
 - immediately call your gas supplier from a neighbor's phone. Follow the gas supplier's instructions.
 - If you cannot reach your gas supplier, call the fire department.
2. This fireplace shall not be installed in a bedroom or bathroom.
3. Never install the fireplace
 - In a recreational vehicle.
 - Where curtains, furniture, clothing, or other flammable objects are less than 36 inches from the front, top, or sides of the fireplace.
 - In high traffic areas.
 - In windy or drafty areas.
4. Do not use this fireplace as a wood-burning fireplace.
5. Do not add extra logs or ornaments such as pine cones, vermiculite, or rock wool. Using these added items can cause soot build-up.
6. This fireplace is designed to be smokeless. If logs appear to smoke, turn off fireplace and call a qualified service person.
7. Avoid any drafts that alter burner flame patterns. Do not allow fans to blow directly into the fireplace. Do not place a blower inside burn area of the firebox. Ceiling fans may create drafts that alter burner flame patterns. Soot build-up and improper burning will occur. Soot build-up can settle on household surfaces outside the fireplace.
8. This fireplace needs fresh air ventilation to run properly.

The Vent free decorative gas log set must have an oxygen depletion sensor (ODS) pilot light safety system. The ODS shuts down the fireplace if not enough fresh air is available. See Air for Combustion and Ventilation, page 8. If the fireplace keeps shutting off, see appliance manufacturers' troubleshooting instructions.

9. Do not run fireplace
 - Where flammable liquids or vapors are used or stored.
 - Under dusty conditions.
10. Do not use this fireplace to cook food or burn paper or other objects.
11. Never place any objects in the fireplace or on logs.
12. Fireplace screens must be provided and are to be closed before operating the decorative room heater. If doors are installed, they must be open during operation. Fireplace front and screen become very hot when running fireplace. Keep children and adults away from hot surfaces to avoid burns or clothing ignition. The fireplace will remain hot for a time after shut down. Allow surfaces to cool before touching.
13. Carefully supervise young children when they are in the room with the fireplace.
14. Do not use fireplace if any part has been exposed to or under water. Immediately call a qualified service technician to inspect the fireplace and to replace any part of the control system and gas control which has been under water.
15. Do not operate the fireplace if any log is broken. Do not operate the fireplace if a log is chipped (dime-sized or larger). Verify proper log placement prior to operating appliance.
16. Turn fireplace off and let cool before servicing. Only a qualified service person should service and repair the fireplace.
17. Operating the fireplace above elevations of 4,500 feet may cause pilot outage.

DO NOT USE OR STORE GASOLINE OR OTHER FLAMMABLE LIQUIDS OR GASES IN OR NEAR THE FIREPLACE!

ATTENTION: A fire or an explosion could occur causing property damage, injury or loss of life if you do not follow the information in this manual!

NOTE: THIS MANUAL MUST BE REPRODUCED ONLY IN ITS ENTIRETY.

Carefully review the instructions supplied with the decorative type unvented room heater for the minimum firebox size requirement.

DO NOT INSTALL THE APPLIANCE IN THIS FIREBOX UNLESS THIS FIREBOX MEETS THE MINIMUM DIMENSIONS REQUIRED FOR THE INSTALLATION.

When choosing a location for your fireplace, avoid locations that are subject to too much draft or locations where you may encounter obstructions that may be in the way of the fireplace once installed. Always check local codes and familiarize yourself with the surrounding construction.

Location

Note: You may need to provide combustion and ventilation air from an outside source to adequately satisfy local codes so avoid installing a combustion air inlet where the opening could be blocked by snow, bushes or other obstacles. Note that the access for outside air inlet is located on the right hand side of the fireplace.

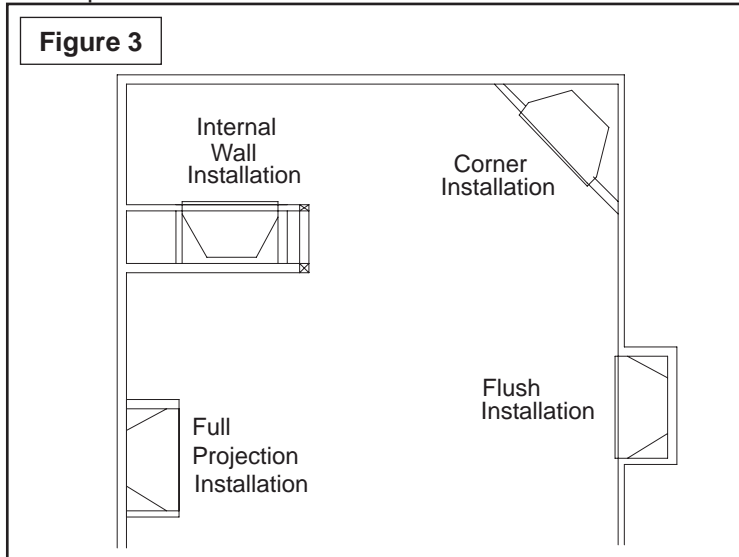

Projected installations can extend any distance into the room. A projection may be ideal for a new addition on an existing, finished wall.

Corner installations make use of space that may not normally be used and provides a wider and more efficient range for heat disbursement.

An internal wall installation provides a discreet option for room separation and can also be ideal as an addition to an existing wall.

IMPORTANT: Vent-free heaters add moisture to the air. Installing a fireplace in rooms without enough ventilation air may cause mildew to form from too much moisture.

IMPORTANT: Make sure the fireplace is level. If the fireplace is not level, the log set will not work properly.

Attention: You may need a building permit to install a MASON-LITE fireplace. Check with the local jurisdiction before you get started.

Supporting Floor Systems

Floor Framing

It is important to take into consideration that the load for the Mason-Lite Fireplace is considerable, but, more important, that it is a dead load that will have to be absorbed by a relatively small amount of existing floor space.

It is the ultimate responsibility of the installer to ensure that proper concrete slab supports are used.

WARNING to the licensed design professional and/or building contractor: It is your responsibility to be certain that the Mason-Lite can be properly supported by the combustible floor system on which the fireplace will rest.

For fireplace support foundations installed on concrete refer to Appendix I and II (**pages 17 & 18**) for specific instructions.

Rebar locations

Lay-out the position of the fireplace and drill holes where the rebar will be located. Secure the #3 rebar 4 inches into the concrete foundation with ITW Epoxy or Simpson Epoxy. Follow manufacturer's instructions for installation of rebar into slab.

Wood Floor

Anchorage of fireplace to wood floor construction is required. Refer to **Figure 8** for anchorage dimensions. Four anchors are required to attach to the sub-flooring framing.

Crawl Space or Upper Floor:

For installation of firebox over combustible crawl spaces or upper floors, anchorage of the firebox is required. Illustrations of examples of possible anchorage methods are shown in Figures 5 thru 7 depending upon the type of floor framing. Final method of anchorage is to be determined by licensed design professional.

A flush installation is recommended where living space is limited or at a premium. Check local codes for any restrictions.

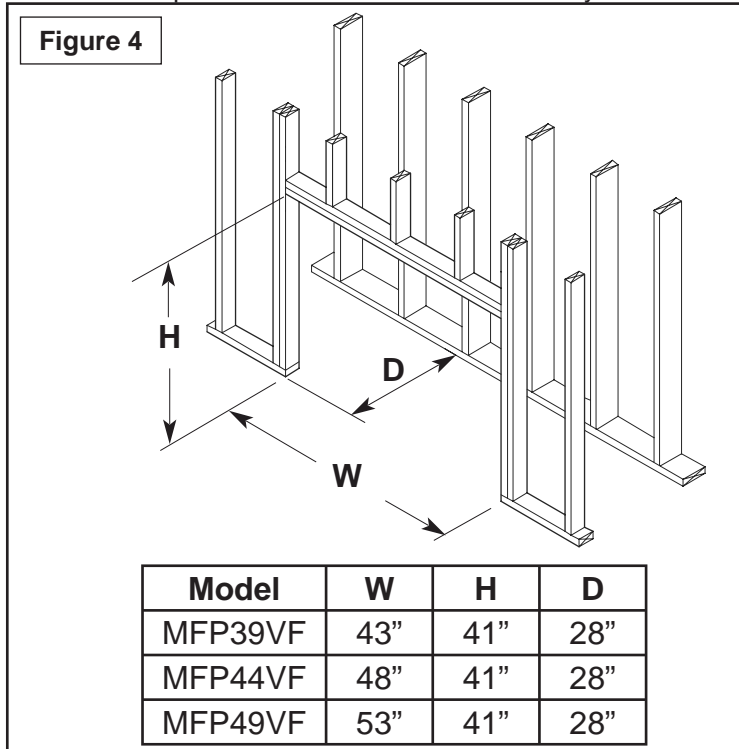

For conventional framing, where the floor joists are parallel with the sides of the firebox, the addition of floor joists to align with the anchor brackets allows the brackets to be directly connected to the floor joists.

Note that additional floor joists may be required to support the weight of the firebox and chimney. Where the floor joists run parallel to the front of the firebox, anchorage can be accomplished in like manner as shown in Figure 5 using blocking between the floor joist.

For floors supported by I-Joists, the method of anchorage is illustrated in Figures 6 and 7. Figure 10 illustrates the general arrangement of anchorage to floor framing.

It is important to take into consideration that the load for the Mason-Lite Fireplace must be considered as additional dead load that will have to be supported by the floor framing. Additional floor joists or I-joists may be required as determined by the licensed design professional.

The dead weights for the fireplace are noted in Table I. It is the task and responsibility of the general contractor/installer to see that the proper reinforcement for weight loads are made by a licensed design professional prior to the fireplace installation.

As stated above, it is desirable to place additional framing for alignment of anchor rods. Refer to Figure 10 for anchor rod locations.

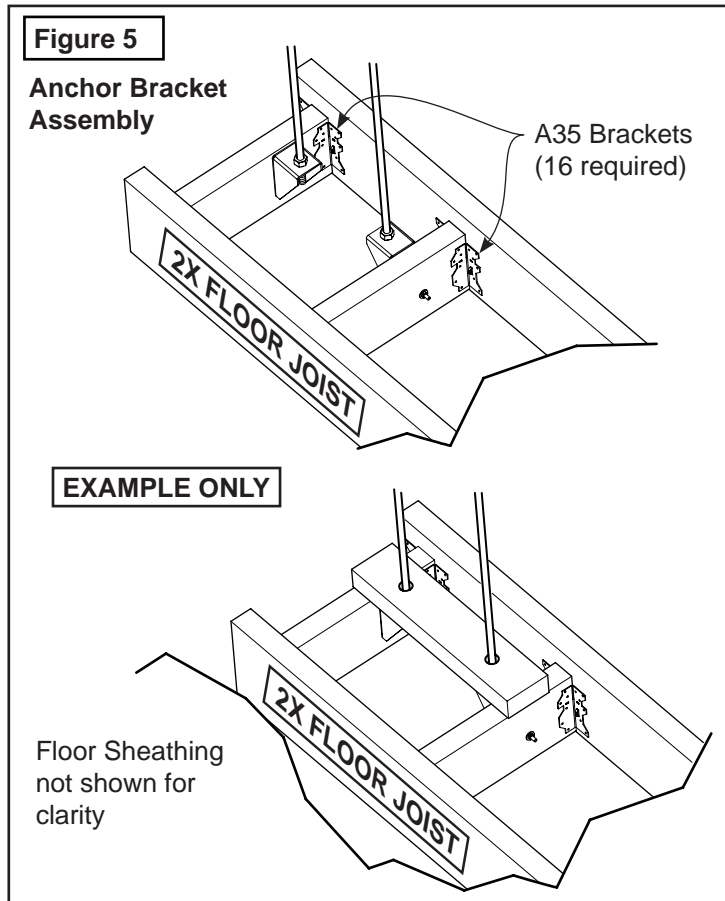
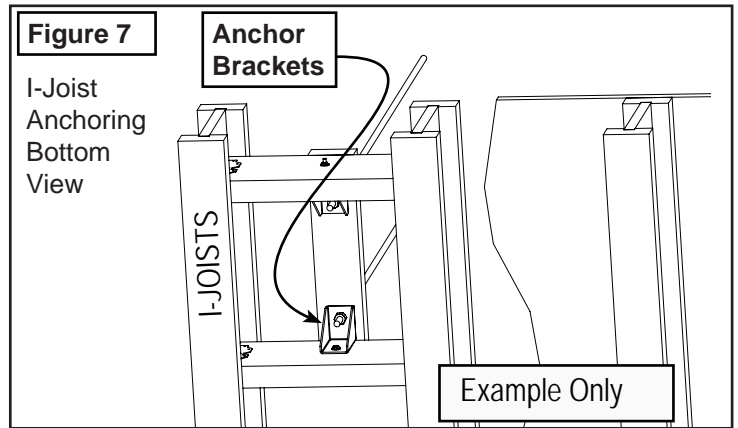
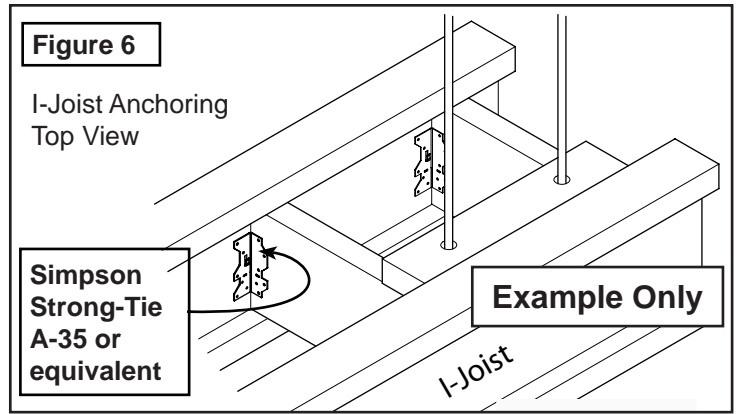

Mason-Lite Weight Determinations

The following are dead load weight estimates for the Mason-Lite Fireplace.

Fireplace Model	MFP39VF	MFP44VF	MFP49VF
Fireplace Weight	809 lbs.	896 lbs.	987 lbs.
Mortar, Rebar & Ready Mix Concrete	350 lbs.	357 lbs.	364 lbs.
Firebrick Lining	333 lbs.	345 lbs.	356 lbs.
Floor Area	43" x 28" (8.12 ft ²)	48" x 28" (9.33 ft ²)	53" x 28" (10.30 ft ²)

Other Weight Considerations:

Fireplace finished facing (surround): This information needs to be obtained from the contractor.

Construction	L	S or W	D + L ₁
Floor Members	1/360	---	1/240

¹ For wood structural members having a moisture content of less than 16 per cent at time of installation and used under dry conditions, the deflection resulting from L + 0.5D is permitted to be substituted for the deflection resulting from L + D.

Note that MASON-LITE cannot accept responsibility for structural floor support details. All drawings are presented as mere illustrations to indicate the presence of the underlying floor system. It is the responsibility of the general contractor/installer to consult with a local licensed design professional for guidance in building a proper floor support system.

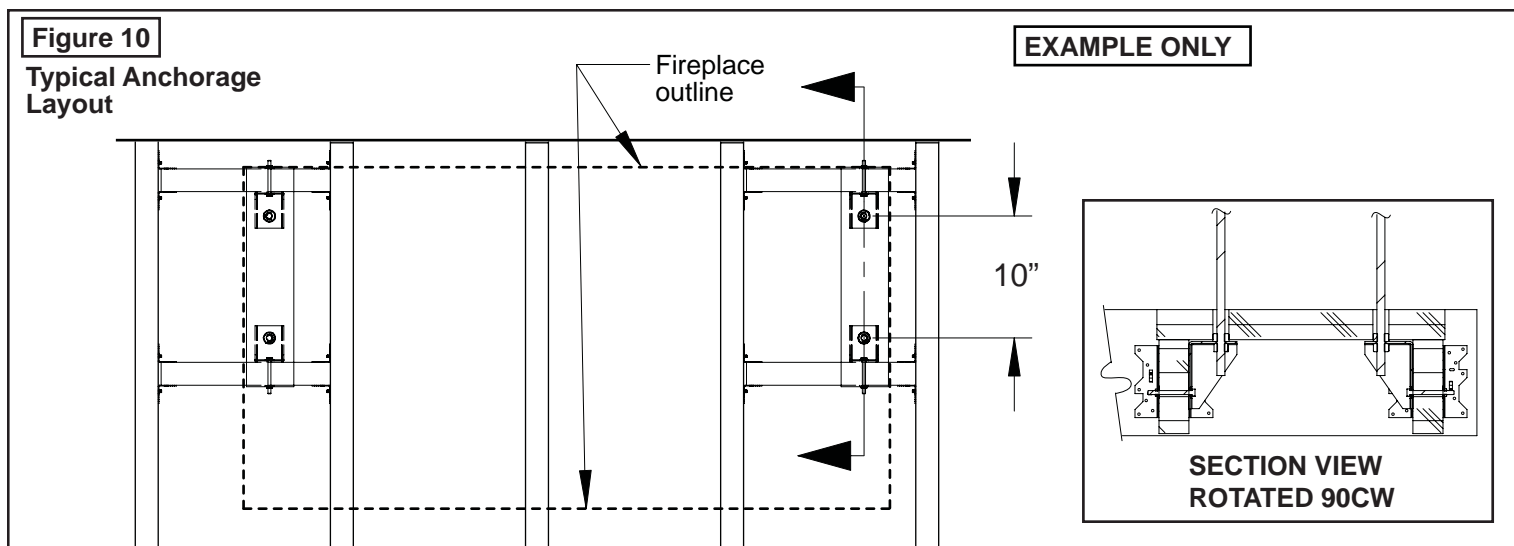
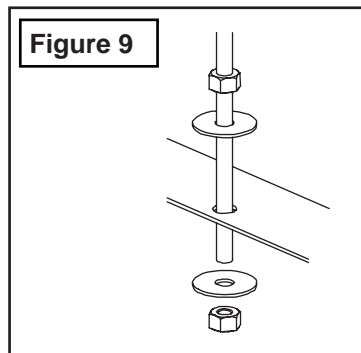
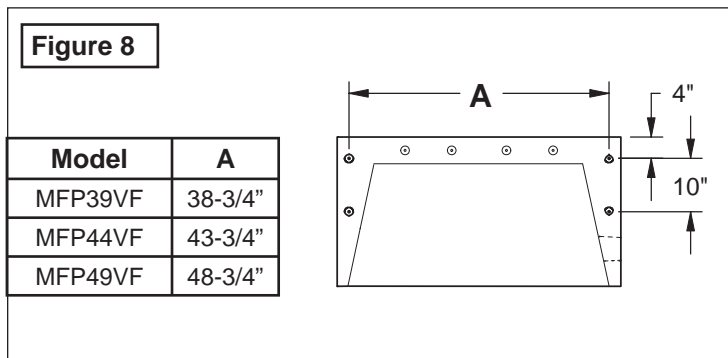

Clearances

The Importance of Clearances

Warning to the structural engineer and/or building contractor: It is your responsibility to be certain that the Mason-Lite can be properly supported by the combustible floor system on which the fireplace will rest. Be advised that this engineering equation will be in addition to any live or dead weights that the floor has to carry.

Clearances to Combustibles

Nothing is more important than paying strict attention to giving clearance between fireplace surfaces and surrounding "combustibles" the most common of which are:

- Drywall
- Wood flooring
- Plywood sub-flooring
- Framing materials
- Particle board
- Mill board
- Plywood paneling

Required Clearances are:

Unit front, sides, rear:	0"
Combustible Floor:	0"
Combustible Sheathing above opening top:	8" (200 mm)
Sheathing or trim to opening sides:	8" (200 mm)
Mantle above opening:	12" (300 mm)
Opening to sidewall:	24" (500 mm)
Insulation from firebox:	0"

The Mason-Lite Vent-Free fireplace may be installed at "zero clearance" to plywood sheathing and to uninsulated wood framing members at the unit bottom, sides, rear and top when used for enclosing any listed vent-free gas-fired log set with maximum heat input ratings up to 40,000 Btu/hr. However, when a Vent-Free fireplace is to be installed on carpeting, wood flooring, or any combustible material other than tile or concrete, the Vent-Free fireplace shall then be installed on a metal or wood platform extending the full width and depth of the Vent-Free fireplace.

Clearance to Combustible Trim:

Mason-Lite Vent-Free Fireplaces are designed to be custom finished with facing trim and mantle to be an owner option. However, all such trim material must meet standard fireplace code requirements.

Non-combustible facing material must be applied to a minimum of eight inches (8") beyond the sides of the finished opening of the Vent-Free fireplace and non-combustible facing material must cover a minimum of twelve inches (12") above the finished opening of the installed unit.

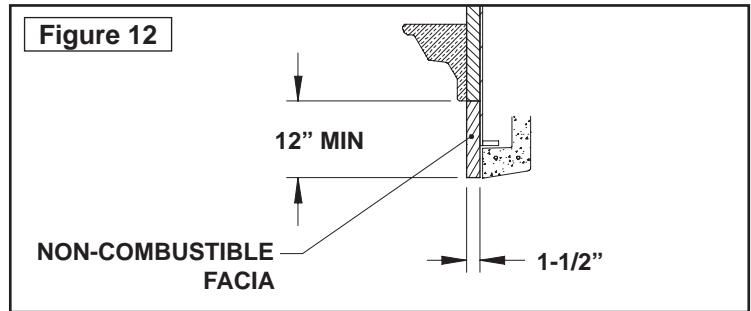
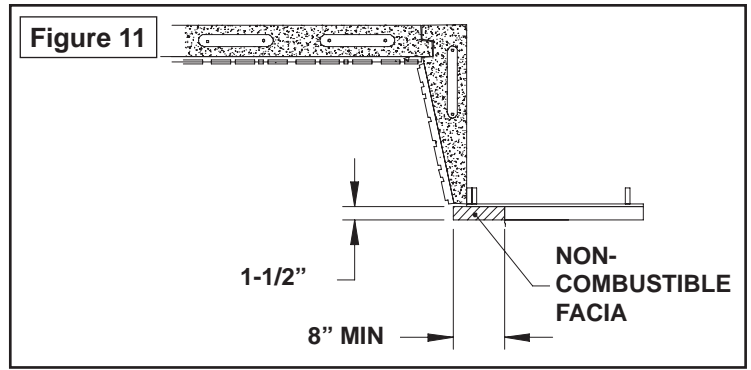

Clearance to combustible trim are those distances required to ensure that combustible mantle and facing material will not be exposed to excessive heat while the unit is operating.

These clearances should be adequate to prevent discoloration or warping of trim facings due to heat. However, circumstances unique to each installation create variables that may be beyond the scope of this manual. Therefore be sure to follow gas log appliance manufacturer's explicit installation instructions regarding all minimum trim facing, mantle height and side wall clearance requirements.

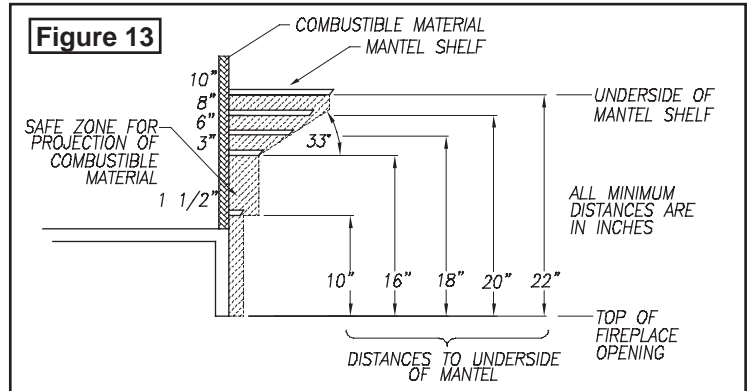

Parts of the combustible mantle assembly located above and projecting more than one and one-half inches (1-1/2") inches from the firebox opening shall be kept at least twelve inches (12") from the top of the opening.

Mantle shelves with horizontal projection of ten inches (10") from the face of the fireplace must be held to a minimum vertical distance of twenty inches (20") from the top of the finished fireplace opening.

Note: Mantle height clearances may vary among gas log appliance manufacturers or with the use of firebox canopies.

Be sure to follow the gas log appliance manufacturer's explicit installation instructions for mantle height clearance requirements.

Interior Wall Materials:

Wall materials, such as drywall, should be set flush with the rough front face of the Vent-Free fireplace. This will allow for placement of required non-combustible surround material in such a way that the surround material can lay flat against the finished wall surface and also align with the leading edge of the fire brick interior of the Vent-Free fireplace (see **Figure 15**).

Trim Facings:

Parts of the combustible mantle assembly located along the sides of the firebox opening, which project more than one and one-half inches (1-1/2") from the face of the fireplace, shall be kept at least eight inches (8") from the firebox opening.

Adjoining Room Walls:

Interior wall surfaces of adjoining room walls must be at a minimum horizontal measure of twenty four inches (24") away from the finished opening of the Vent-Free fireplace.

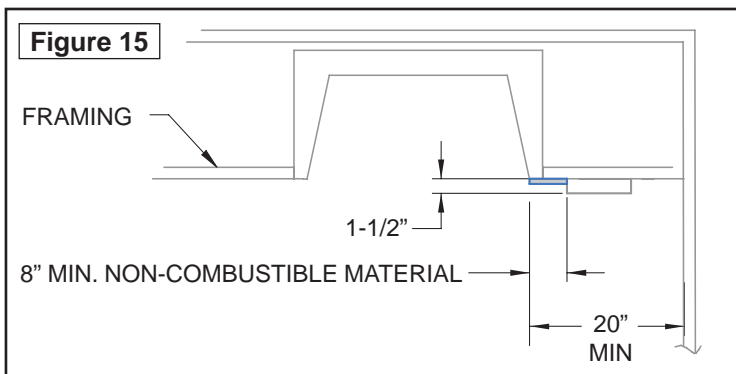
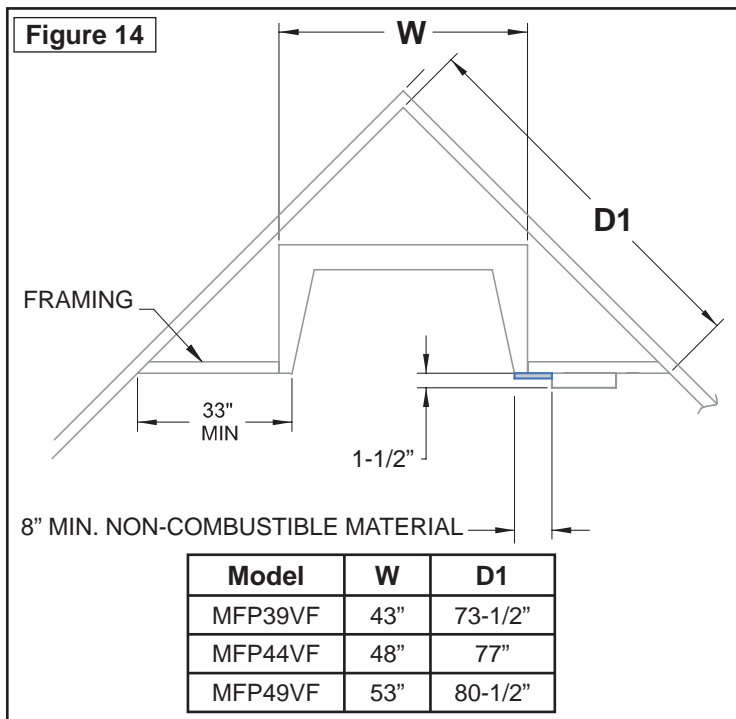

Air for Combustion and Ventilation

Energy efficient homes require homes to be airtight but at the same time provide sufficient fresh air to breathe. Fresh air enters the home through air conditioning duct vents, around doors and windows but also must provide enough fresh air for proper combustion on **all** fuel-burning appliances in the home. Exhaust fans, fireplaces, clothes dryers, and fuel-burning appliances draw air from the house to operate. You must provide adequate fresh air for these appliances. This will insure proper venting of vented fuel-burning appliances.

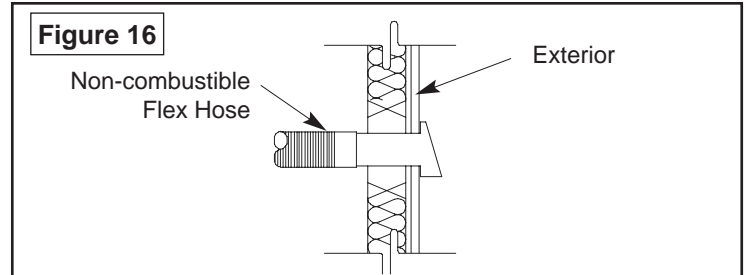

Providing Adequate Ventilation

In accordance with the National Fuel Gas Code NFPA 54/ANSI Z223.1, Section 5.3, Air for Combustion and Ventilation, all spaces in homes fall into one of the three following ventilation classifications:

1. Unusually Tight Construction
2. Unconfined Space
3. Confined Space

The following information will help you classify your space and provide adequate ventilation.

Unusually Tight Construction

The air that leaks around doors and windows may provide enough fresh air for combustion and ventilation. However, in homes of unusually tight construction, you must provide additional fresh air. Unusually tight construction is defined as construction where:

- a. Walls and ceilings exposed to the outside atmosphere have a continuous water vapor retarder with a rating of one perm* or less with openings gasketed or sealed and...
- b. Weather stripping has been added on operable windows and doors and...
- c. Caulking or sealants are applied to areas such as joints around window and door frames, between sole plates and floors, between wall-ceiling joints, between wall panels, at penetrations for plumbing, electrical, and gas lines, and other openings.

* A perm is a unit of permeance or water vapor transmission, the US perm-inch is defined as the passage of 1 grain of vapor through 1 square foot of 1 inch thick material in 1 hour under a pressure difference of 1 inch of mercury.

If your home meets all the three criteria above, you must provide additional fresh air.

Unconfined Space

An unconfined space has a minimum total air volume of 50 cu.ft. (cubic feet) for each 1,000 Btu/Hr input rating of all appliances in the total space (cu.ft. = length x width x height of space). Include adjoining rooms only if there are doorless passageways or ventilation grills between the rooms. If the Btu per 50 cu.ft. is less than 1,000 Btu/Hr, then fresh air will be provided by the natural air flow into the house.

Confined Space

A confined space has an air volume of less than 50 cu.ft. for each 1,000 Btu/Hr input rating of all appliances in the space (cu. ft. = length x width x height of space). Include adjoining rooms only if there are door less passageways or ventilation grills between the rooms.

Determining Total Air Volume

Use this work sheet to determine if you have a confined or unconfined space. The space to be considered includes not only the room in which you will install the fireplace but also any adjoining rooms with ventilation grills between them or door less passageways.

1. Determine the total volume of your space

$L \times W \times H = \underline{\hspace{2cm}}$ cu.ft.

Example: Space size = 20 ft. long x 20 ft. wide x 8 ft. high (ceiling height) = 3,200 cu.ft.

If adjoining ventilation to adjoining room is supplied with grills or openings, add the volume of these rooms to the total volume of the space.

2. Divide the space volume by 50 cu.ft. to determine the maximum Btu/Hr the space can support.

$\underline{\hspace{2cm}}$ cu.ft. (volume of space)

$50 \text{ cu. ft.} = (\text{Maximum Btu/Hr the space can support})$

Example: $3200 \text{ cu. ft. (Volume of space)} / 50 \text{ cu. Ft.} = 64.0$ or $64,000$ (maximum Btu/Hr the space can support.)

3. Add the Btu/Hr of all fuel burning appliances in the space.

Vent-free fireplace	<u> </u>	Btu/hr
Gas water heater*	<u> </u>	Btu/hr
Gas furnace	<u> </u>	Btu/hr
Vented gas heater	<u> </u>	Btu/hr
Gas fireplace logs	<u> </u>	Btu/hr
Other gas appliances*	<u> </u>	Btu/hr
Total =	<u> </u>	Btu/hr

Example: Gas water heater 40,000 Btu/hr
Vent-free fireplace +36,000 Btu/hr
Total = 76,000 Btu/hr

* Do not include direct-vented gas appliances. Direct vent draws combustion air from the outdoors and vents to the outdoors.

4. Compare the maximum Btu/Hr the space can support with the actual amount of Btu/Hr used.

 Btu/Hr (maximum the space can support)
 Btu/Hr (actual amount of Btu/Hr used)

Example:
64,000 Btu/Hr (maximum the space can support)
76,000 Btu/Hr (actual amount of Btu/Hr used)

The space in the previous example was a confined space because the actual Btu/Hr used was more than the maximum Btu/Hr the space could support. If you find you have a Confined Space, you must provide additional fresh air. Your options are as follows:

- a) Re-work worksheet, adding the space of an adjoining room that may not have qualified for the extra volume. If the extra space provides enough volume to convert the area to an unconfined space, remove door to adjoining room or add ventilation grills between rooms.
- b) Vent room directly to the outdoors.
- c) Install a lower Btu/Hr gas log (if lower Btu/Hr size makes room unconfined).

If the actual Btu/Hr used is less than the maximum Btu/Hr the space can support, the space is an unconfined space. You will need no additional fresh air ventilation.

WARNING: If the area in which the heater may be operated is smaller than that defined as an unconfined space, provide adequate combustion and ventilation air by one of the methods described in the National Fuel Gas Code, ANSI Z223.1 Section 5.3 or applicable local codes.

Local codes may have stricter definitions for confined space and/or for unusually tight construction. Installing our optional outside air kit may allow the space to be classified as not being unusually tight or being an unconfined space. Check you local codes.

IMPORTANT: Do not provide openings for inlet or outlet air into an attic if the attic has a thermostat-controlled power vent. Heated air entering the attic will activate the power vent.

Important Pre-installation Information

Overview

You will find that the Mason-Lite Fireplace is designed for complete assembly at your construction site with all necessary items delivered consisting of interlocking precast parts, 50 lbs. of Mason-Lite mortar and rebar.

The parts of the fireplace are made of Mason-Lite's incredibly strong blend of specialty cement and a lightweight aggregate.

The design of the fireplace calls for the installation of a refractory fire brick liner. This should be a minimum of 1-1/8" thick. The liner will be applied within the walls of the firebox. Modular firebrick panels are also available from MFI.

Additional Materials Required:

- 1) Ready-Mix concrete - 2 cu.ft.

SURFACE CRACKS - The MASON-LITE FIREPLACES are manufactured using high quality materials. During the drying process, surface cracking may occur. These small cracks (under 1/16" will not affect the fireplace safety or performance). During the assembly process, fill surface cracks with thin-set mortar and brush when drying for a smooth surface finish.

Leveling and Aligning Components:

It is important to assemble all Vent-Free fireplace components flush, level and square. Since it is not intended that mortar be used to lay a mortar joint of any measurable thickness as is typical when laying brick or concrete block, adjustments in component height and level alignments are accomplished with the use of small shims. These shims can be tapped into place to level and align components. Once the Mason-Lite Mortar is set, the shims must be removed completely.

Be sure to re-grout any and all gaps where shims have been inserted and then removed or where contact surfaces have been separated by shim leveling.

Field Assembly Procedures

- 1) Mixing the MASON-LITE mortar – You will require a 50 lb. bucket of MASON-LITE mortar which will be more than enough to adequately affix all the fireplace components, one to the next. The mortar is premixed and dry and is to be used to adhere all the fireplace components. Be sure to use clean water and work it up into a mixture that is pasty but not lumpy. If it is too thin, the components will not adhere. Some trial and error may be necessary. You will want to apply the mixture with a standard grout bag.
- 2) Moisten all surfaces which will have grout applied prior to assembly. This will minimize shrinkage and cracks developing in the joint areas. Best way to accomplish this is with a bucket of water and a large sponge. Dip sponge into water and apply a liberal amount of water to the grout joint surface several minutes before the part is to be assembled. The water will absorb into the surface allowing the grout to properly cure.
- 3) Assembly of the Components – Once you have found the proper consistency of the mixture, load it into the grout bag

and then place the components together applying the mixture directly to the components where they come together. As a rule, you can figure that you should lay down about 1/2" (one-half inch) of a thread of mortar. The line of mortar should be approximately 1/2" (one-half inch) away from all the edges of each separate component.

The mortar has a considerable amount of holding power so do not overload the components with too much mortar.

- 4) You will notice that some mortar will "ooze out" when you place the next component on top of or next to the component you previously place. This is to be expected – it means the two pieces have properly bonded -- and you will want to swipe the excess away with a trowel. It is never intended that the surfaces of the MASON-LITE components are to be completely covered with mortar.
- 5) Do not apply the mortar in thick bands even if the component you are working with is larger than the rest. You will want to apply "stripes" of mortar in these situations.
- 6) Making Sure Components Are Level – It is extremely important that you pay careful attention to how you are assembling the MASON-LITE. Since every component builds on the next, it is critical, that from the beginning, you are checking that the components are fitting together to be level and flush. If you have to make any kind of an adjustment, do not try to do it "by loading an opening" with mortar. That is completely unacceptable, resulting in a fireplace that will not be plumb or level. What you are advised to do is make use of shims. You will find these supplied with the MASON-LITE and you can nudge them in between openings to achieve the precision you need in making component adjustments.
- 7) Once you have removed the shims, you will want to cover any gaps that may have resulted with the grout.

Warning: All surfaces where grout is applied must have water sponged on several minutes prior to assembly. This will minimize cracking of grout joint and provide maximum strength.

Fireplace Assembly Procedures

Note - Wipe excess water from surface prior to applying grout. This will help grout to adhere to surface during assembly.

Warning: All surfaces where grout is applied must have water sponged on several minutes prior to assembly. This will minimize cracking of grout joint and provide maximum strength.

Place the Mason-Lite Fireplace hearth base on top of your non-combustible floor. For concrete slabs, supporting floor needs to be rated at ASTM 90.

- 1) Draw an outline of the hearth area based on the dimensions shown in **Figure 17**. Position Hearth slabs and mark rebar center locations. Drill 4 inches into concrete slab and secure the 8 pieces of 12 inch rebar with epoxy.

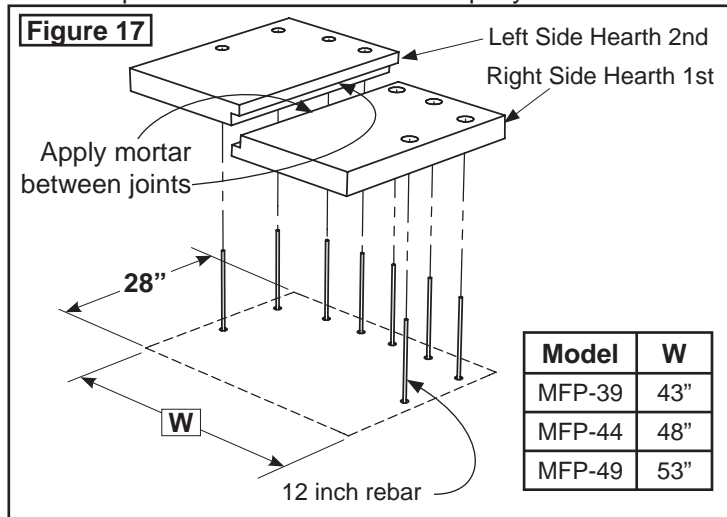

- 2) Mix a batch of mortar and prepare Right Side Hearth bottom surface to be bonded as shown in **Figure 18**.

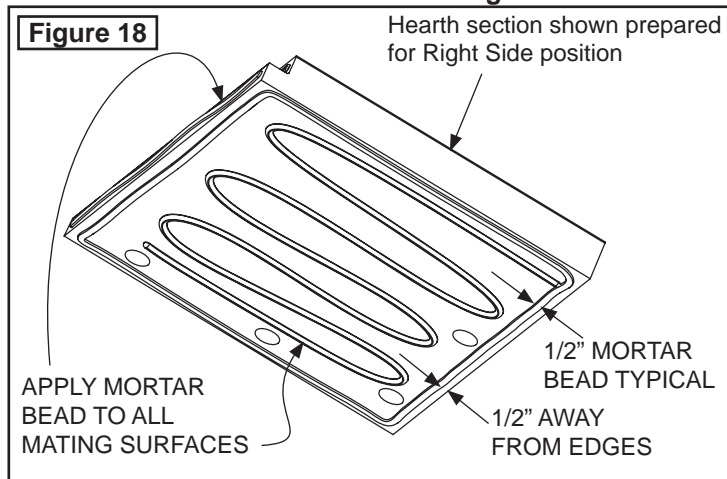

- 3) Align Right Side Hearth to the outline created. The overall width should allow for an approximate gap of 1/8" between slabs for the additional mortar to unite the remaining slab. Check for surface flatness, level if necessary.
- 4) Apply mortar to the remaining Hearth except this time apply beading on surface to be facing floor as shown in **Figure 19**.

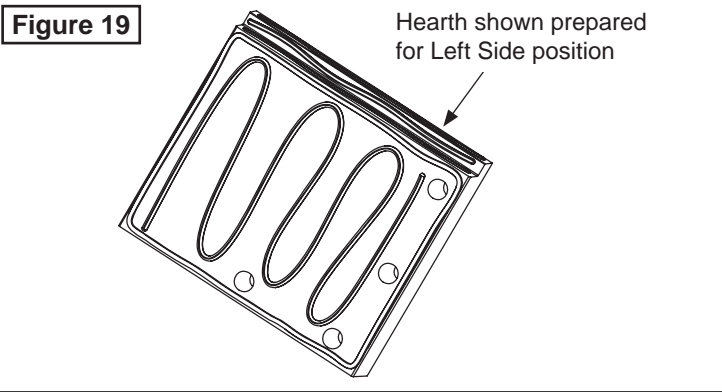

- 5) Before installing side walls, confirm placement of outside combustion air access (if required), this can be installed either side depending on which side is accessible to outside combustion air (all diagrams in this manual show the combustion air inlet hole on the right side). Prepare side wall and rear wall mating surfaces with the prepared mortar and begin assembly.

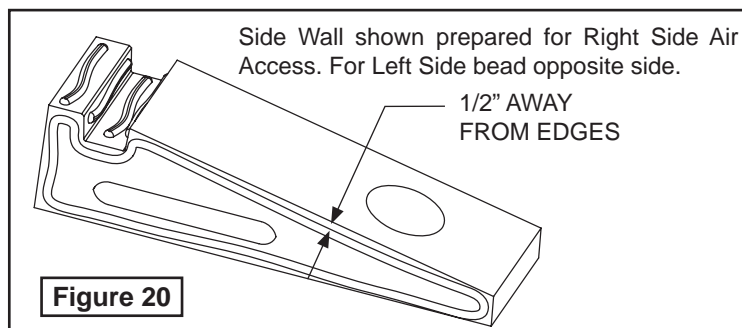

- 6) Keep the assembly of the next sections of the firebox side walls moving up, keeping components moist, mixing mortar as you need it and threading the mortar appropriately as you stack each section, one onto the next. Constantly check for squareness and levelness while building each course of block. As you complete each section, make certain that you adhere the mortar at each and every joint.

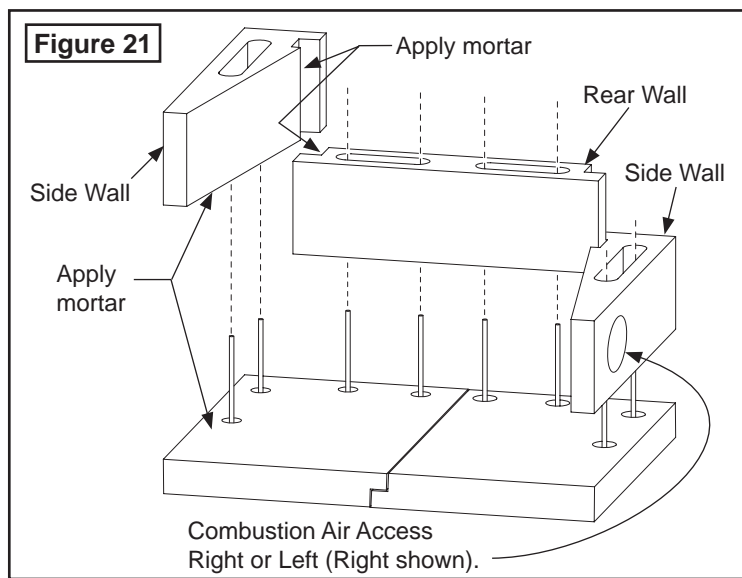

- 7) When you have arranged all the components into place and you are working on the top rear firebox, check that your work is level. If you need to, you can make some adjustments in the top surface of the box assembly simply by using shims. Once you are satisfied with the degree of levelness, you can address any gap that may have occurred with an appropriate amount of mortar.

Although you are cautioned to use Mason-Lite mortar sparingly because it does have such holding power, you should look over the firebox assembly at the end and fill any gaps with mortar especially at joint connections. Adjustments must be made to ensure the fireplace is level and square while the mortar is still wet.

- 8) After fourth row of walls are in place, add 36" rebar to all cells as shown in **Figure 22**. The rebar should enter the holes in the Hearth and lie adjacent to the 12" rebar secured in subfloor. Then fill cells with approx. 2 cu.ft. Ready-Mix Concrete.

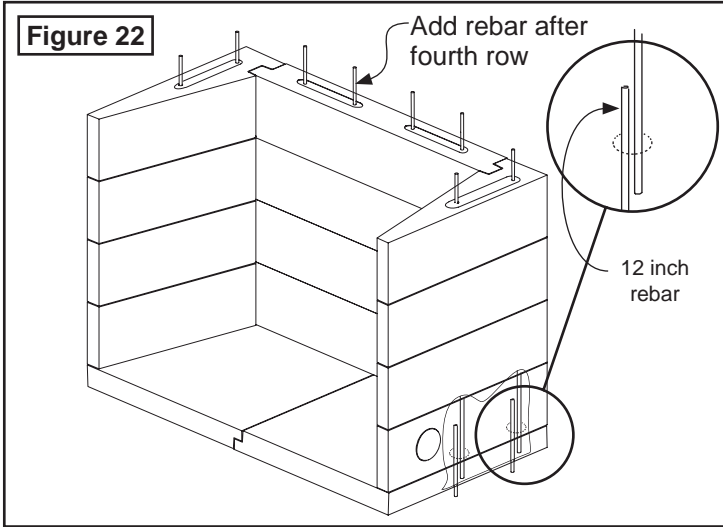

- 9) Temporarily place Lintel between side walls, making sure it is flush to the front and snug at the inside. Check for alignment. Remove Lintel and apply mortar on surfaces to be mated. Install Lintel.

- 10) Install Lower Rear Dome flush to the rear walls as shown in **Figure 23**.

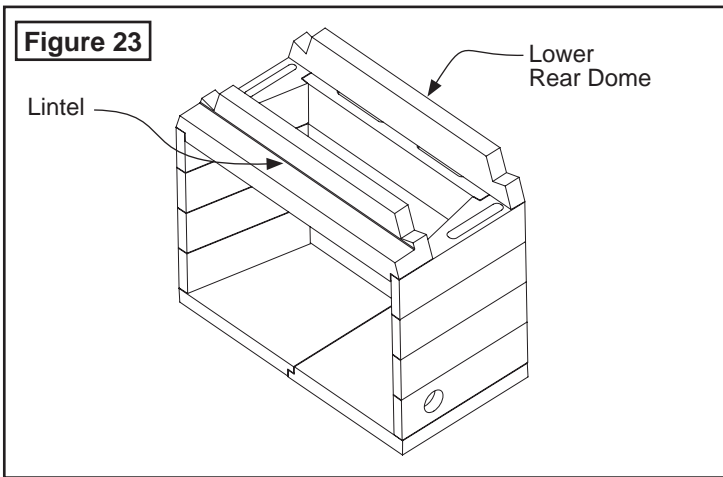

- 11) Place Lower Side Domes between Lintel and Lower Rear Dome to verify fit. The face with the rating plate faces the inside of the firebox as shown in **Figure 24**. Remove and prepare mating surfaces with mortar. Assemble Lower Dome Sides and check that all four top surfaces are level with each other. Shim if necessary.

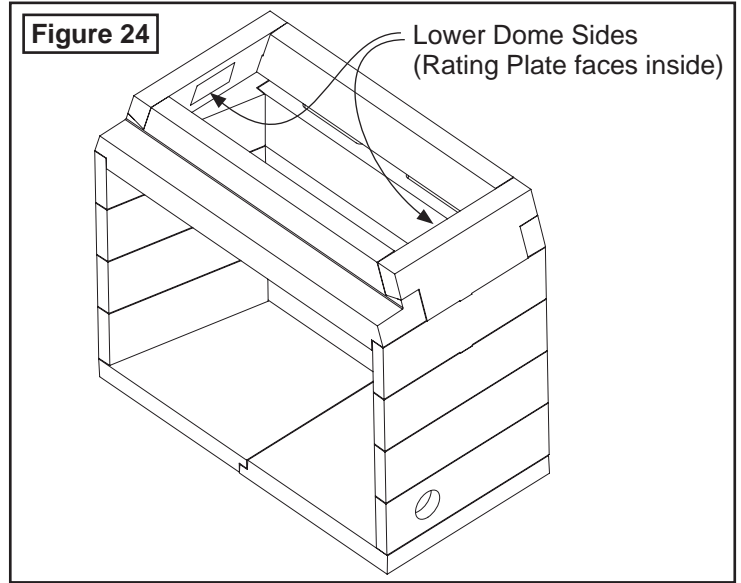

- 13) Now install the Smoke Dome Tops. Align outer edges with Lower Dome Sides. Check for flatness and squareness.

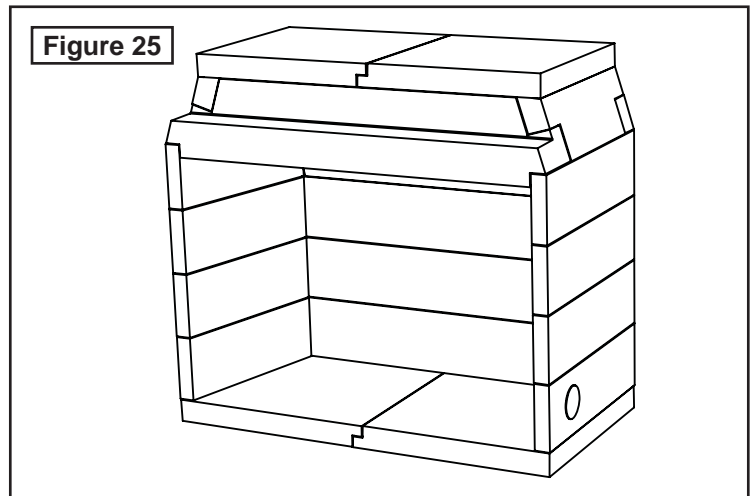

Raised and Flush Hearth Application:

If you would prefer to have a raised hearth, the Vent-Free box can be raised to the desired height using wood studs or concrete blocks.

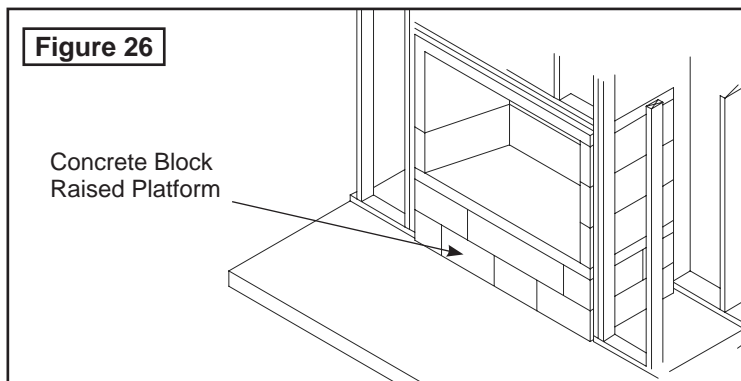

When determining raised hearth height, be sure to allow for the 3" thick firebox hearth and 1-1/2" thick firebrick floor, in addition to the height of base platform.

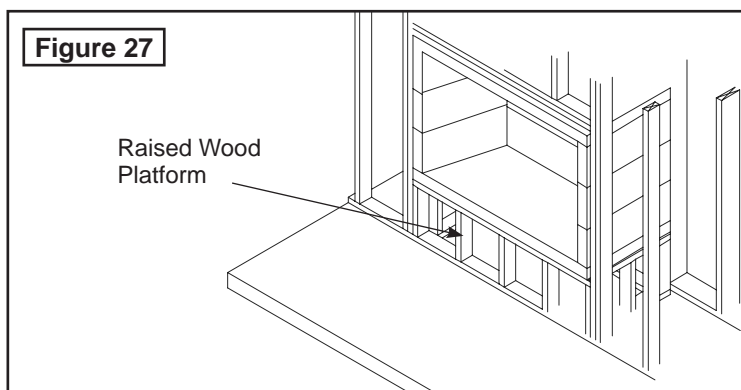

For a "flush hearth" (fireplace floor flush with the room's floor) the base plate can be omitted from the assembly and the firebox walls built directly on the concrete support slab. The fire brick floor of the firebox is then set directly to the concrete support slab. This makes the fireplace finished fire brick floor approximately one and one-half inches (1-1/2") above the top of the concrete support slab.

Gas Piping Installation

The provision for installation of a gas pipe is only for connection to a Vent free decorative gas log sets meeting standard ANSI Z21.11.2

Familiarize yourself with requirements for installation as outlined by the National Fuel Gas Code, ANSI Z223.1.

This gas pipe provision must only be connected to an approved vent-free gas log heater certified to ANSI Z21.11.2 heater standard. Check local building codes for specific pipe and material requirements.

- 1) Gas piping can be routed from the floor, rear or side walls. With a masonry drill, follow the instructions from the gas appliance manufacturer. Any wires must be routed through separate conduit. Make sure provisions are made for access to manual shut-off valve.

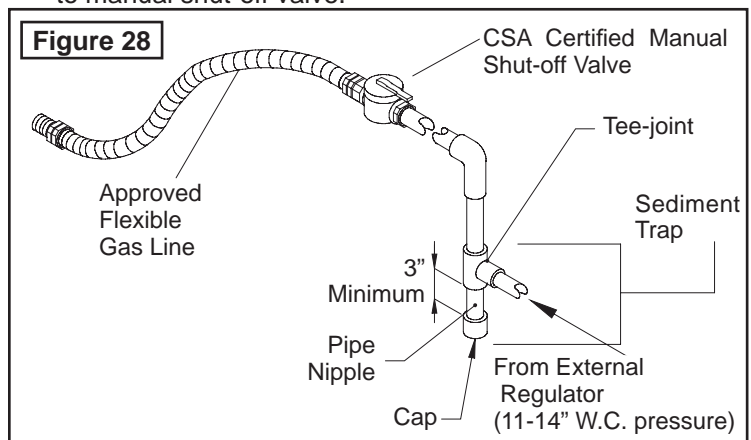

- 2) After routing piping, fill hole around pipe with MASON-LITE mortar.

Electrical Line Feed

Electrical line feed can be routed through the Standard firebox back wall, side walls or floor by drilling an appropriately sized hole using a masonry drill bit. Be sure to follow the Vent free decorative gas log Manufacturer's explicit electrical line connection instructions for vented masonry fireplace installations.

NOTE: Gas line and electric line must be routed through separate access holes.

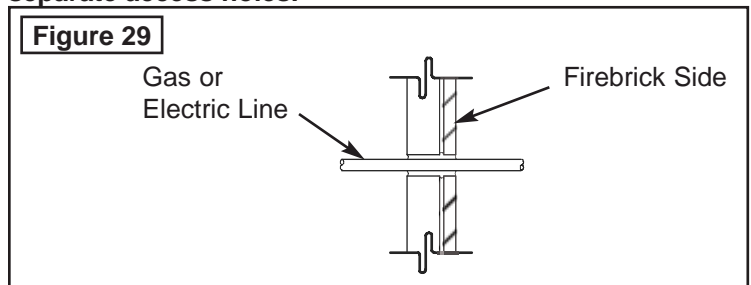

IMPORTANT: All access holes must be grouted with mortar to seal any gaps or cracks.

Firebrick Liner Installation

It is required that the interior sides, rear and bottom be lined with minimum 1-1/8" thick firebrick. Mason-Lite Pre-fabricated fire brick liner walls can make the installation easier.

All required through-wall accesses (gas and electrical line feeds and combustion air supply access holes) should be drilled before the required fire brick lining is installed.

Modular Firebrick Lining

If using our Mason-Lite Firebrick Liners, simply use an extra bucket of mortar. Install Hearth Liner first, rear next and sides last. Consider if brackets for grates will be required, also if pre-drilling is required for gas lines, electrical or if the outside combustion air kit is to be installed.

The following Firebrick Patterns are available from MFI:

MFP(XX)SHBL- Herring Bone

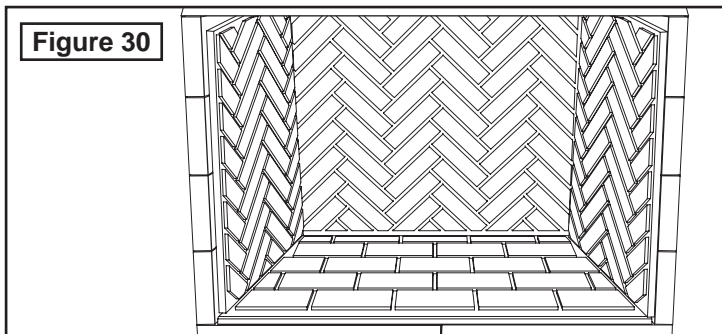

MFP(XX)FRBL- Running Bond

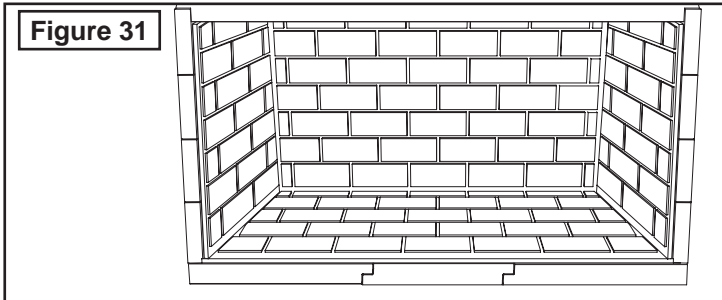

Initial Fireplace Operation

Follow the gas appliance manufacturers' requirements for lighting and operating your vent free log. When first operating the fireplace, open a window in the room to allow smells created from the heater and fireplace curing.

We suggest operating the heater for several 30 minute intervals allowing the fireplace to cool for an hour in between. This will allow any moisture in the brick and fireplace to escape.

Keep in mind that it may require several operations to completely remove any smell from the operation of a vent-free heater and fireplace. If this condition continues, contact your gas appliance dealer to inspect the gas heater for proper operation.

Appendix I

For installations regulated by the International Residential Code, the support foundation for the fireplace installed on concrete shall consist of a minimum of 6 inches thick reinforced concrete slab. The minimum specified compressive strength of f'_c , shall be as required in Table R402.2 of the International Residential Code (IRC). Concrete subject to moderate or severe weathering as indicated in Figure R301.2(3) of the International Residential Code (IRC) shall be air entrained as specified in Table R402.2 of the International Residential Code (IRC). The maximum weight of fly ash, other pozzolans, silica fume, slag or blended cements that is included in concrete mixtures for garage floor slabs and for exterior porches, carport slabs and steps that will be exposed to deicing chemicals shall not exceed the percentages of the total weight of cementitious materials specified in Section 4.2.3 of ACI 318. Materials used to produce concrete and testing thereof shall comply with the applicable standards listed in Chapter 3 of ACI 318.

For installations regulated by the International Building Code (IBC), the support foundation for the fireplace installed on concrete shall consist of a minimum of 6 inches thick reinforced concrete slab. The concrete strength and durability shall comply with Sections 1903, 1904 and 1905 of the International Building Code (IBC).

TABLE R402.2 MINIMUM SPECIFIED COMPRESSIVE STRENGTH OF CONCRETE

TYPE OR LOCATION OF CONCRETE CONSTRUCTION	MINIMUM SPECIFIED COMPRESSIVE STRENGTH^a (f'_c)	
	Negligible	Moderate or Severe Weathering Potential^b
Basement walls, foundations and other concrete not exposed to the weather	2,500	2,500 ^c
Basement slabs and interior slabs on grade, except garage floor slabs	2,500	2,500 ^c
Basement walls, foundation walls, exterior walls and other vertical concrete work exposed to the weather	2,500	3,000 ^d
Porches, carport slabs and steps exposed to the weather, and garage floor slabs	2,500	3,000 ^{d,e,f}

- a. Strength at 28 days psi.
- b. See Figure R301.2(3) for weathering potential.
- c. Concrete in these locations that may be subject to freezing and thawing during construction shall be air-entrained concrete in accordance with Footnote d.
- d. Concrete shall be air-entrained. Total air content (percent by volume of concrete) shall be not less than 5 percent or more than 7 percent.
- e. See Section R402.2 for maximum cementitious materials content.
- f. For garage floors with a steel troweled finish, reduction of the total air content (percent by volume of concrete) to not less than 3 percent is permitted if the specified compressive strength of the concrete is increased to not less than 4,000 psi.

Appendix II

FIGURE R301.2(3) WEATHERING PROBABILITY MAP FOR CONCRETE

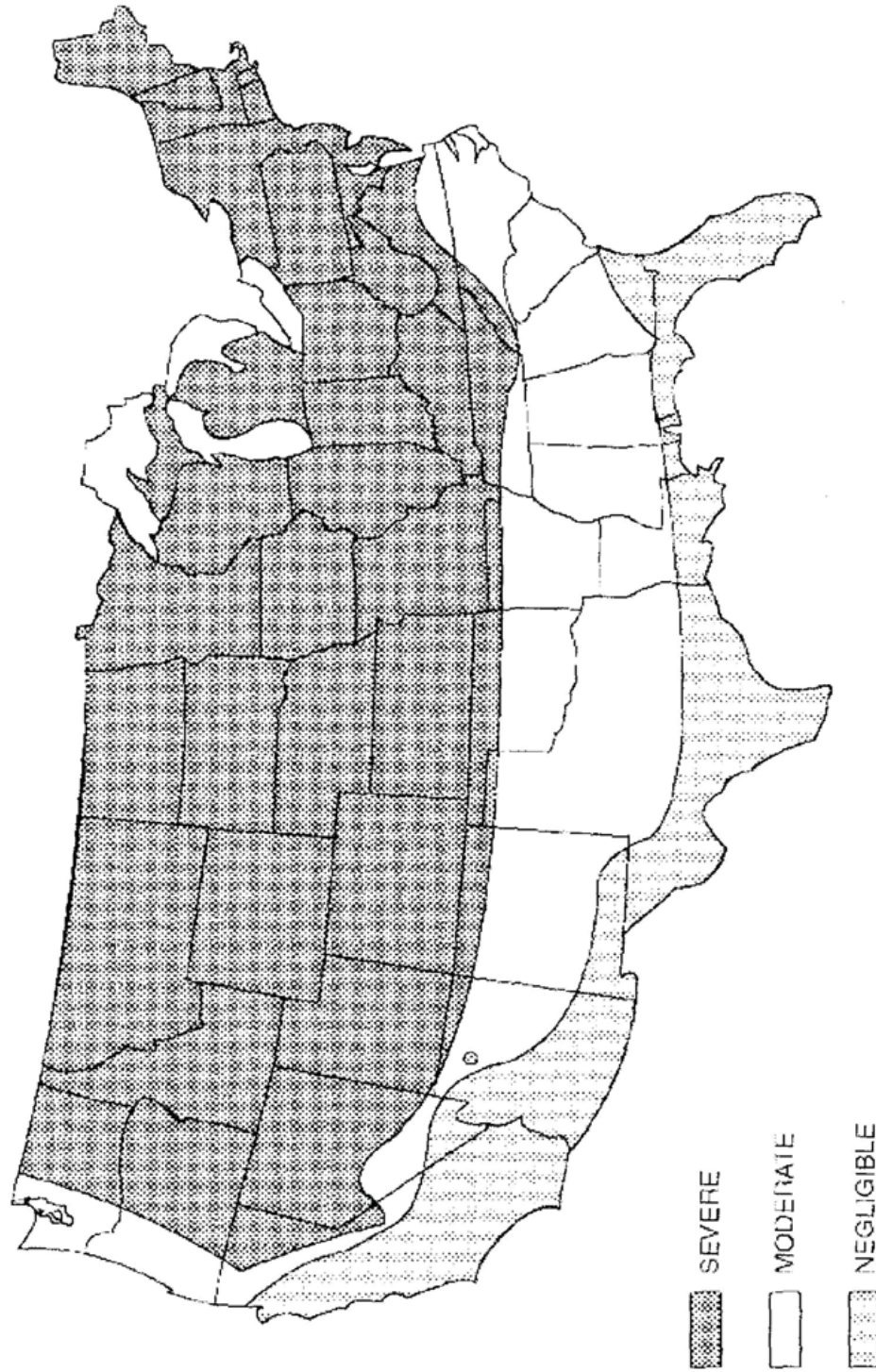

- a. Alaska and Hawaii are classified as severe and negligible, respectively.
- b. Lines defining areas are approximate only. Local conditions may be more or less severe than indicated by region classification. A severe classification is where weather conditions result in significant snowfall combined with extended periods during which there is little or no natural thawing causing deicing salts to be used extensively.

Limited Warranty Mason-Lite Fireplace

Masonry Fireplaces Industries, LLC (MFI) warrants all MASON-LITE Fireplaces to be free from defects in materials that adversely affect fireplace performance for a period of ten (1) year from the date of purchase, subject to the terms and conditions of this limited warranty. MFI does not warrant accessory chimney, outside air ducts, gas control or burner system, ceramic logs, and devices not manufactured by MFI.

This warranty covers only products manufactured by MFI, specifically the modular concrete firebox, and NO WARRANTY, EXPRESS OR IMPLIED, EXTENDS TO ANY OF THE HARDWARE, FOUNDATION, VENTING, DUCTS, OR ACCESSORIES. THIS WARRANTY DOES NOT COVER DRAFTING, SMOKING, OR SOOTING OF THE FIREPLACE SYSTEM. Factors beyond the manufacturer's control affect drafting, smoking, and sooting and MFI cannot guarantee these aspects of performance.

If a component is found to be defective under the terms of this warranty, the party this warranty is extended to shall notify MFI, 315 W. 3rd Street, Santa Ana, CA 92701 in writing, by registered mail, within thirty (30) days following the discovery of the defect within One (1) year warranty period. The letter shall contain (1) the date of purchase; (2) place of purchase; (3) address of installation; (4) name, address and phone number of the homeowner; and (5) a brief description of the defect.

MFI, or any entity thereof, is not responsible for any labor costs or indirect costs incurred for the replacement of defective components.

MFI is not responsible for misuse or mishandling of component parts. Nothing in this warranty makes MFI, or any entity thereof, liable in any respect for any injury or damage to the building or structure in which the fireplace has been installed or to the persons or property therein arising out of the use, misuse, or installation of properly manufactured MFI product.

MFI, OR ANY ENTITY THEREOF, SHALL NOT BE HELD LIABLE FOR ANY INCIDENTAL OR CONSEQUENTIAL DAMAGES OR EXPENSES ARISING OUT OF THE USE OF THE FIREPLACE. ALL SUCH DAMAGES AND EXPENSES ARE HEREBY EXCLUDED.

This warranty is null and void when the fireplaces are not installed pursuant to the installation instructions provided by MFI and local building codes have not been followed completely.

This warranty applies only to those fireplaces installed in the continental United States, Hawaii, Alaska and Canada. If any part of this warranty is found to be unenforceable,, the remaining parts shall remain in force and effect.

MFI HEREBY DISCLAIMS ALL GUARANTEES AND WARRANTIES, EXPRESS OR IMPLIED, BEYOND THE WARRANTIES SET FORTH HEREIN.

CUSTOMER SERVICE & PARTS REPLACEMENT:

Parts and accessories may be purchased from your local dealer. Additional information is available from Masonry Fireplace Industries, L.L.C. Accessory orders will be accepted by mail, or you may call to order Monday through Friday from 1:00 p.m. to 5:00 p.m. (Pacific Standard Time) at: (800) 345-7078.

Please complete the following information for future reference and warranty verification:

Date of Purchase _____ **20** _____

Model # _____

Serial # _____