



FMI PRODUCTS, LLC

**SEE-THRU WOOD BURNING FIREPLACE
OWNER'S OPERATION AND INSTALLATION MANUAL**



We recommend that our products be installed and serviced by professionals who are certified in the U.S. by NFI (National Fireplace Institute).
www.nficertified.org

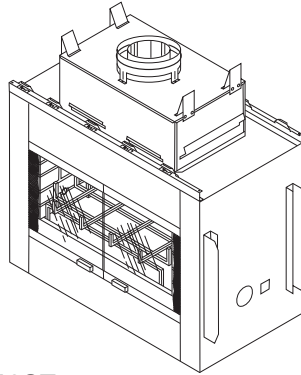

Models (V)3612ST

SAVE THIS BOOK

This book is valuable. In addition to instructing you on how to install and maintain your appliance, it also contains information that will enable you to obtain replacement parts or accessory items when needed. Keep it with your other important papers.

This fireplace is approved for use as a wood burning fireplace or for use with a vented gas log approved to ANS Z21.60 or Z21.84 standards or for use with a vent-free gas log heater approved to ANS Z21.11.2 standard.

This wood burning fireplace complies with UL127-CAN/ULS-S610-M87 standard as a **FACTORY BUILT APPLIANCE**.

FOR CANADA: The authority having jurisdiction (such as the municipal building department, fire department, etc.) should be contacted before installation to determine the need to obtain a permit.

INSTALLER: Leave this manual with the appliance.
CONSUMER: Retain this manual for future reference.

For more information, visit www.fmiproducts.com

WARNING: Improper installation, adjustment, alteration, service or maintenance can cause injury, property damage or loss of life. Refer to this manual for assistance or additional information. Consult a qualified installer or local distributor.

TABLE OF CONTENTS

Safety Information	2	Optional Gas Line Installation.....	12
Product Dimensions	3	Operation and Maintenance Guidelines	13
Fireplace Installation.....	4	Technical Service.....	14
Venting Installation	6	Replacement and Accessory Parts.....	15

SAFETY

IMPORTANT: Check local codes before installing this fireplace.

Models (V)3612ST series is a wood burning fireplace intended and approved for installation in either residential homes or buildings of standard construction. This fireplace system requires the utilization of FMI PRODUCTS, LLC 12" double wall, snap-lock flue pipe system.

Glass doors are optional with this fireplace and come in different styles. For more information see *Glass Doors*, page 13).

Before beginning the installation of the fireplace, read these instructions through completely.

- This FMI PRODUCTS, LLC fireplace and its components are safe when installed according to this installation manual. Use only FMI PRODUCTS, LLC components, which have been designed and tested for the fireplace system. Failure to do this may cause a fire hazard.
- The FMI PRODUCTS, LLC warranty will be voided by and FMI PRODUCTS, LLC disclaims any responsibility for the following actions.
 - a. Modification of the fireplace, components, doors, air inlet system and damper control.
 - b. Use of any component part not manufactured or approved by FMI PRODUCTS, LLC in combination with a FMI PRODUCTS, LLC fireplace system.

Proper installation is the most important step in ensuring safe and continuous operation of the fireplace. Although grounding may not be required by code in your area, it must be electrically grounded in accordance with local codes or, in the absence of local codes, with the *National Electrical Code, ANSI/NFPA 70*.

This fireplace is intended for installation in ac-

cordance with the *National Fire Protection Association Standard for Chimneys, Fireplaces, Vents and Solid-Fuel Burning Fireplaces, NFPA 211*, and in accordance with codes such as the *BOCA Basic/National Code, the Standard Mechanical Code*, and the *Uniform Building Code*.



WARNING: Do not install a fireplace insert in this firebox unless the manufacturer's instructions with the insert specifically state this fireplace has been tested for use with the insert.

This fireplace is not intended to be used as a substitute for a furnace to heat an entire home. Use for supplemental heat only.

FOR YOUR SAFETY

- Do not store or use gasoline or any other flammable vapors or liquids in the vicinity of this or any other appliance.
- Due to high temperatures, the appliance should be located out of traffic and away from furniture and draperies.
- Do not place clothing or other flammable materials on or near the appliance.
- Never leave children unattended when a fire is burning in the fireplace.

SAFETY

Continued

WARNING: Use solid wood or processed solid fuel fire logs only. When processed wood fuel fire logs are used, do not poke or stir the logs while they are burning. Use only fire logs that have been evaluated for the application in fireplace and refer to fire log warnings and caution markings on packaging prior to use.

WARNING: Always leave glass doors fully opened or fully closed when operating fireplace.

WARNING: Children and adults should be alerted to the hazards of high surface temperatures and to stay away to avoid burns or clothing ignition. Young children should be carefully supervised when in the same room as fireplace.

PRODUCT DIMENSIONS

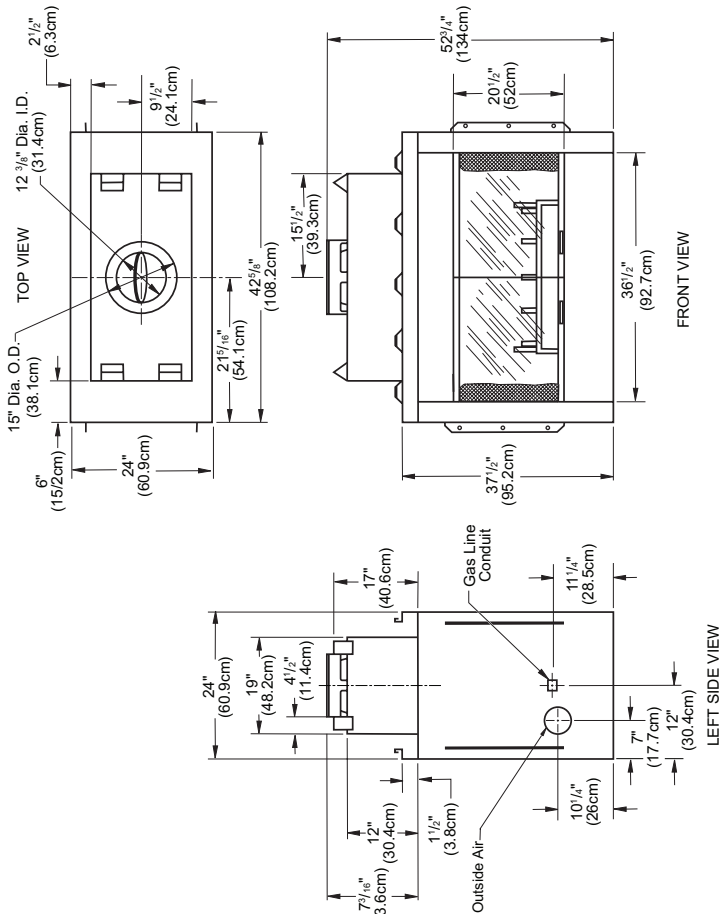

Figure 1 - (V)3612ST Dimensions

FIREPLACE INSTALLATION

SELECTING LOCATION

To determine the safest and most efficient location for the fireplace, you must take into consideration the following guidelines:

1. The location must allow for proper clearances (see Figure 2).
2. Consider a location where the heat output will not be affected by drafts, air conditioning ducts, windows or doors.
3. A location that avoids the cutting of joists or roof rafters will make installation easier.
4. If an outside air kit is to be installed, accessibility to outside combustion air must be considered. This can also be achieved through a vented crawl space in some cases (see Optional Outside Air Kit on page 6).

The typical installation for a (V)3612ST is a projected installation which allows you to extend the fireplace any distance into the room. A projection may be ideal for a new addition on an existing, finished wall.

MINIMUM CLEARANCE TO

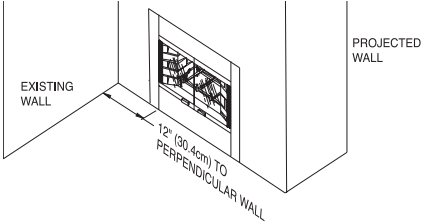

Figure 2 - Common Location of Fireplace

COMBUSTIBLES

Back and sides of fireplace	1/2" min.
Adjacent wall	12" min.
Chimney outer pipe surfaces	2" min.
Bottom of fireplace to floor	0" min.

⚠ WARNING: Do not block required air spaces with insulation or any other material. Do not obstruct effective opening of fireplace with any type of facing material. Combustible material must not be in contact with black front face of fireplace.

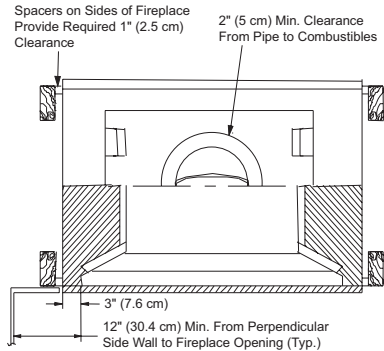

Figure 3 - Fireplace Clearances

FRAMING

1. Frame the opening for the fireplace using the dimensions shown in Figures 4 and 5 and Figure 6 on page 5.

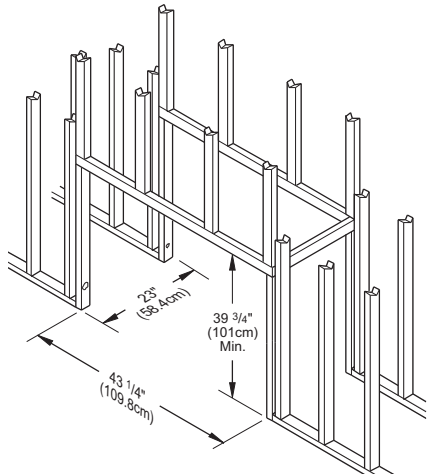

Figure 4 - Framing Firebox

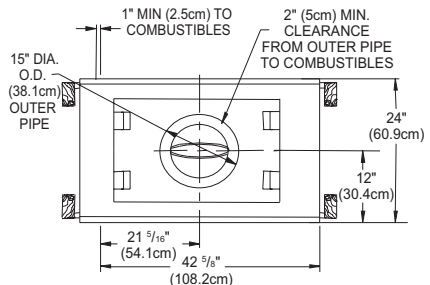

Figure 5 - Framing Clearances

FIREPLACE INSTALLATION

Continued

- If fireplace is to be installed directly on carpeting, tile (other than ceramic) or any combustible material other than wood flooring, fireplace must be installed upon a metal or wood panel extending full width and depth of fireplace.
- Set fireplace directly in front of opening and slide unit back until nailing flanges touch side framing.
- Check the level of fireplace and shim with sheet metal if necessary.
- Before securing fireplace to prepared framing, ember protector (provided) must be placed between hearth extension (not supplied) and under bottom front edge of fireplace to protect against glowing embers falling through (see Figure 7). If fireplace is to be installed on a raised platform, a Z-type ember protector (not supplied) must be fabricated to fit your required platform height (see Figure 6). The ember protector should extend under fireplace a minimum of 1 1/2". The ember protector should be made of galvanized sheet metal (28 gauge minimum) to prevent corrosion.
- Using screws or nails, secure fireplace to the framing through flanges located on sides of the fireplace (see Figure 8).

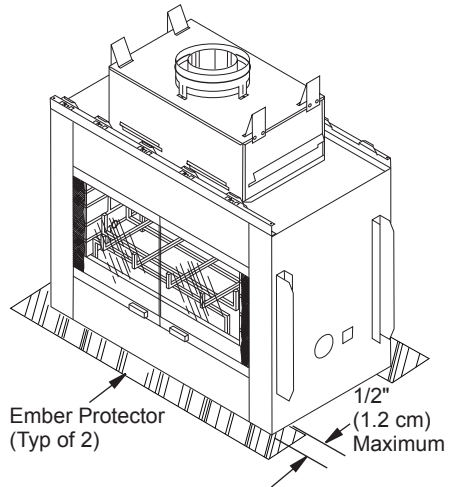

Figure 7 - Ember Protectors

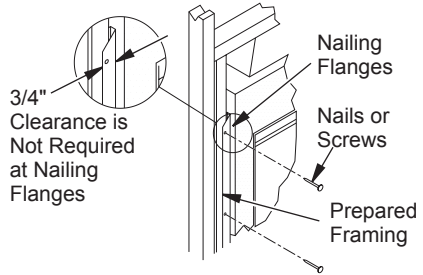

Figure 8 - Nailing Flanges

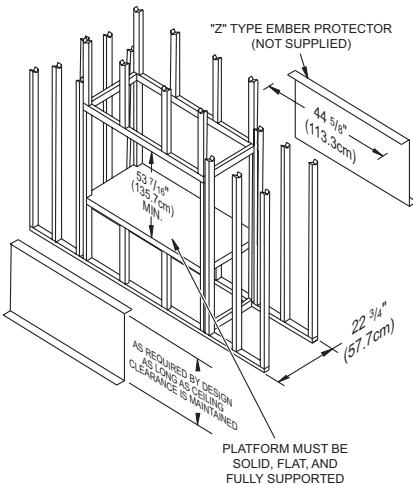

Figure 6 - Framing Firebox with "Z" Type Ember Protectors

HEARTH EXTENSION

A hearth extension projecting a minimum of 16" in front of and a minimum of 8" beyond each side of the fireplace opening is required to protect combustible floor construction in front of fireplace (see Figure 9, page 6). Fabricate a hearth extension using a material which meets the following specifications: a layer of noncombustible, inorganic material having a thermal conductivity of $K=0.84$ BTU IN/FT, HR. F (or less) at 1" thick. For example, if the material selected has a K factor of 0.25, such as glass fiber, the following formula would apply:

$$\frac{0.25 \times 1.0"}{0.84} = 0.30" \text{ thickness required}$$

Thermal conductivity "K" of materials can be obtained from manufacturer or supplier of noncombustible material.

If hearth extension is to be raised, a "Z" type ember protector must be used (see Figure 6 and Figure 10, page 6)

FIREPLACE INSTALLATION

Continued

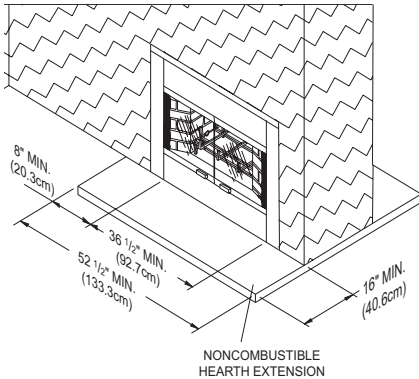

Figure 9 - Hearth Extensions

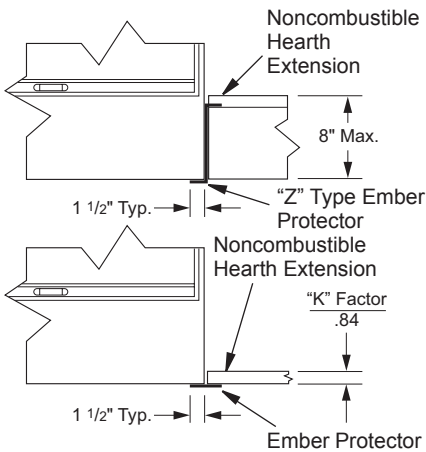

Figure 10 - Raised Hearth Extension

MANTEL CLEARANCES

Woodwork such as wood trims, mantels or any other combustible material projecting from

the front face must not be placed within 9" of fireplace opening.

Combustible materials above and projecting more than 1 1/2" from the fireplace front face (see Figure 11) must not be placed less than 12" from effective opening of the fireplace (*NFPA STD 211, Sec. 7-3.3.3*).

Mantels or any other combustible material may also come up to the side edge of the black metal face of the fireplace only if the projection from the front face falls within limits shown in Figure 12.

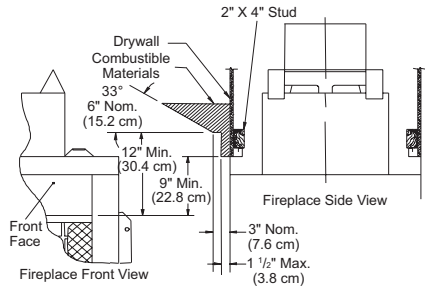

Figure 11 - Mantel Clearances to Combustible Materials

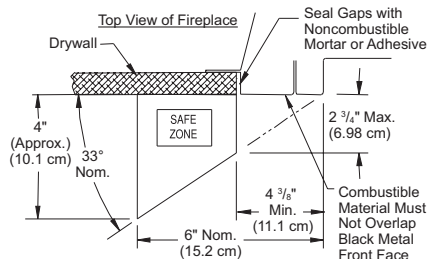

Figure 12 - Mantel Clearances to Metal Face

VENTING INSTALLATION

OPTIONAL OUTSIDE AIR KIT

The installation of an outside air kit should be performed during the rough framing of the fireplace due to the nature of it's location. Outside combustion air is accessed through and exterior wall or a vented crawl space.

CAUTION: Air inlet ducts must not terminate in attic space.

Maximum height for air inlet above the fireplace platform must be no less than 3 feet below chimney cap.

For further details on installation of outside air kit, please refer to instructions included with air kit.

VENTING INSTALLATION

Continued

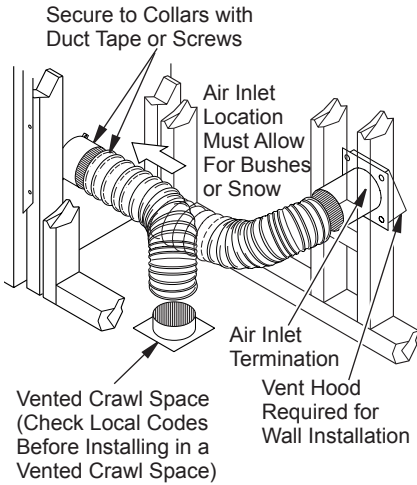

Figure 13 - Outside Air Kit Installation

CHIMNEY PIPE

The FMI PRODUCTS, LLC chimney is a snap-lock, double-wall pipe. It consists of a stainless steel inner flue pipe(s), a galvanized outer pipe and a wire spacer.

Each section of pipe comes in lengths of 12", 18" 36" and 48". The actual lineal gain for each is measured after each section is fully connected. Lineal gain is the actual measurable length of a part after two or more parts are connected.

LINEAL GAIN		
PART NO.	DESCRIPTION	GAIN
V3612ST	See-Through Fireplace	52 ³ / ₄ "
48-12DM 48-12TM	Flue Pipe	46 ⁵ / ₈ "
36-12DM 48-12TM	Flue Pipe	34 ⁵ / ₈ "
24-12DM 48-12TM	Flue Pipe	22 ⁵ / ₈ "
18-12DM 48-12TM	Flue Pipe	16 ⁵ / ₈ "
12-12DM 48-12TM	Flue Pipe	10 ⁵ / ₈ "
STL-12D	Chase Style Termination	1" to 12"
RLT-12D	Round Top Termination	7"

PIPE INSTALLATION

The pipe sections must be assembled independently as the chimney is installed. When connecting chimney directly to the fireplace, the inner flue pipe section must be installed first with the lanced side up. The outer pipe section can then be installed over the flue pipe section with the hemmed end up. Press down on each pipe section until the lances securely engage the hem on the fireplace starter. The wire will assure the proper spacing between the inner and outer pipe sections.

Continue to assemble chimney sections as outlined above, making sure that both the inner and outer pipe sections are locked together. When installing double wall snap-lock chimney together, it is important to assure the joint between the chimney sections is locked. Check by pulling chimney upward after locking. The chimney will not come apart if properly locked. It is not necessary to add screws to keep the chimney together (exception, see Figure 17, page 8).

⚠ WARNING: The opening in the collar around the chimney at the top of the fireplace must not be obstructed. Never use blown insulation to fill the chimney enclosure.

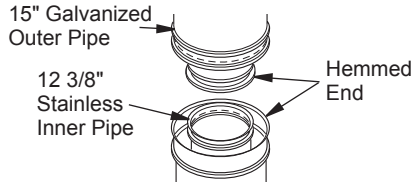

Figure 14 - Pipe Connection

USING ELBOW OFFSETS AND SUPPORTS

Chimney weight above offset rests on return elbow. Straps must be securely nailed to rafters or joists (see Figure 15, page 8).

To achieve desired offset, you may install combinations of 12", 18", 36" and 48" length of double wall pipe (see offset chart and Figure 16, page 8).

The chimney support section is a 4" strap and 12" length of pipe. A chimney support is required every 30 feet above fireplace after a straight chimney run or above a return elbow after a straight chimney run (see Figure 17, page 8). This support is designed to relieve the extra weight load on fireplace and elbows when high chimneys are installed.

VENTING INSTALLATION

Continued

Maximum length of pipe between supports is 6' of angle run. Maximum of two 6' angle run sections per chimney system (see Figure 9, page 8).

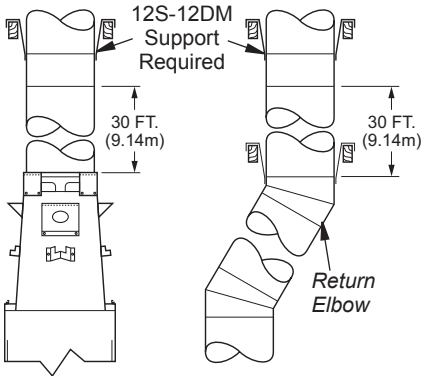

Figure 15 - Elbow Offset

OFFSET A	RISE B	CHIMNEY LENGTH			
		48"	36"	18"	12"
4 3/8"	16 3/8"	ELBOW SET ONLY			
9 1/2"	25 1/4"		1		
12 1/2"	30 3/8"			1	
14 3/8"	34"				2
17 5/8"	39 1/4"			1	1
21 1/2"	46"		1		
22 3/4"	48 1/8"			1	2
26 3/8"	54 7/8"	1			
26 3/8"	60"		1	1	
31 3/4"	63 3/4"	1		1	
34 3/4"	69"	1		1	
38 5/8"	75 5/8"		2		
39 7/8"	77 7/8"	1		1	1
43 3/4"	84 1/2"	1	1		
46 3/4"	87 3/4"		2	1	
48 7/8"	93 3/8"	2			

OFFSET CHART

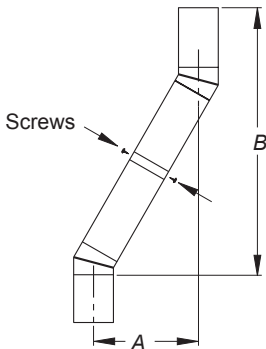

Figure 16 - Rise and Offset

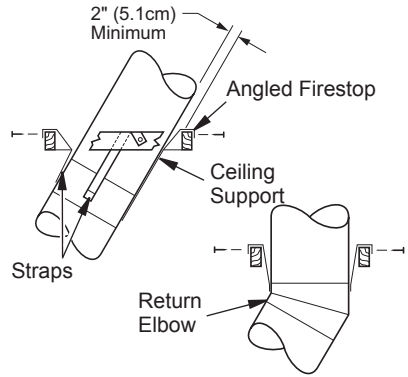

Figure 17 - Chimney Supports

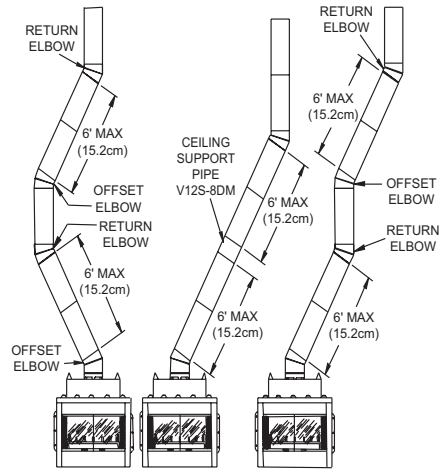

Figure 18 - Typical Offset Installations

FIRESTOP SPACERS (FS-10)

Firestop spacers are required at each point where the chimney penetrates a floor or ceiling joint space. Their purpose is to establish and maintain the required clearance between the chimney and the combustible materials. When the pipe passes through a framed opening into a living space above, the firestop must be placed onto the ceiling from below as shown in Figure 19, page 9.

They also provide complete separation from one floor space to another or attic space as required by most codes. When the double wall pipe passes through a framed opening into an attic space, the firestop must be placed into an attic floor as shown in Figure 20, page 9.

When penetrating a floor or ceiling at an angle, use firestop spacer number 30 FS-10D (see Replacement and Accessory Parts, page 15).

VENTING INSTALLATION

Continued

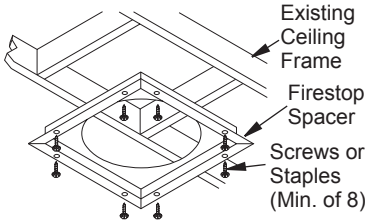

Figure 19 - Firestop Spacer with Living Space Above Ceiling

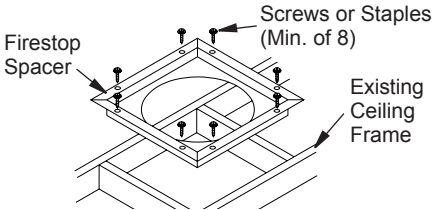

Figure 20 - Firestop Spacer with Attic Space Above Ceiling

10 FOOT RULE

All chimney terminations must extend a minimum of 3 feet above the highest point where it passes through the roof and must be at least 2 feet above roof with a 10 foot horizontal span (see Figure 21).

IMPORTANT: If an exposed portion of chimney is greater than 4 feet above the roofline, use support wires to keep chimney secure. Support wires may be attached to outer pipe of chimney with screws, if screws do not penetrate inner flue pipe.

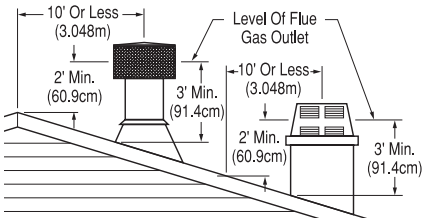

Figure 21 - 10 Foot Rule

MINIMUM / MAXIMUM CHIMNEY HEIGHT

The minimum height of the chimney (measured from the base of the fireplace to the flue gas outlet-end of pipe) is 16 feet for a straight run, 16 feet minimum for a run with 1 elbow set and 25 feet minimum for a run with 2 elbow sets. (A set consists of one starter elbow and one return elbow.)

Uncommon circumstances such as neighboring hills, tall trees, or strong wind areas can cause down drafts in chimney system. In such cases, going beyond the minimum recommended height would be preferable to provide a better draw.

The fireplace height approved for any chimney run with this fireplace system is 40 feet measured from bottom of fireplace to flue outlet-end of pipe (see Figure 22).

⚠ WARNING: Do not operate an unvented gas log set in this fireplace with the chimney removed.

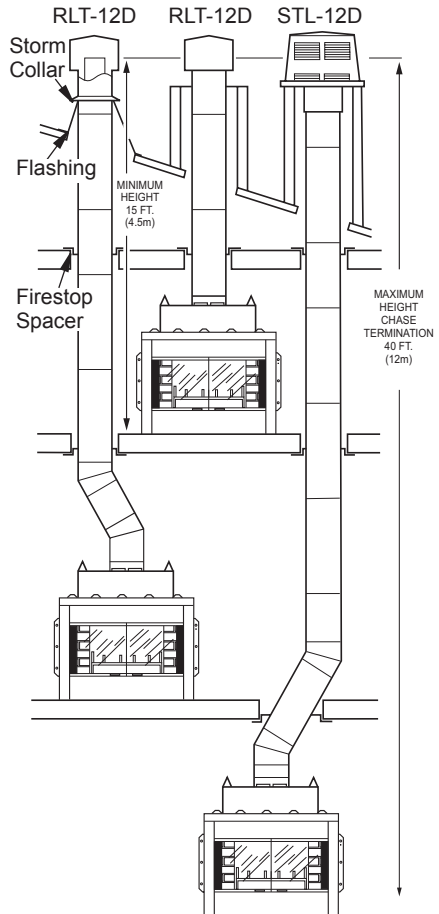

Figure 22 - Maximum Chimney Height

VENTING INSTALLATION

Continued

PENETRATING ROOF

To maintain a 2" clearance to pipe on a roof with a pitch, a rectangular opening must be cut.

1. Determine the center point through which pipe will penetrate roof.
2. Determine center point of roof. Pitch is the distance the roof drops over a given span, usually 12". A 6/12 pitch means that the roof drops 6" for each 12" one measure horizontally down from roof rafters.
3. Use roof opening chart (Figure 23) to determine correct opening length and flashing required.
4. Remove shingles around opening measured. Cut out this section.
5. Add next sections of pipe until end penetrates roof line. Check to see that proper clearances are maintained. Extend chimney by adding sections of double wall pipe until pipe is minimum of 30" above highest point of roof cutout. Termination and chimney must extend a minimum of 36" above highest point where it passes through the roof.

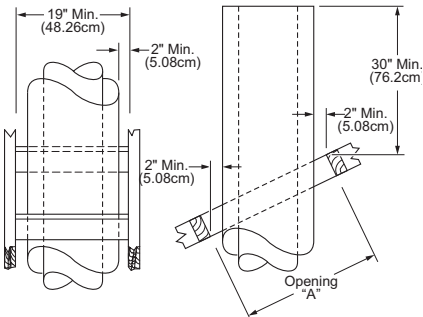

Pitch	Slope	Opening "A" Max.	Used Flashing Model No.
Flat	0°	19"	V6F-10DM
0-6/12	26.6°	23.25"	V6F-10DM
6/12-12/12	56.3°	30.75"	V12F-10DM

Figure 23 - Roof Opening Measurements

FLASHING INSTALLATION

Determine flashing to be used with roof opening chart. Slide flashing over pipe until base is flat against roof. Replace as many shingles as needed to cover exposed area and flashing base. Secure in position by nailing through shingles (see Figure 24). **DO NOT NAIL THROUGH FLASHING CONE.**

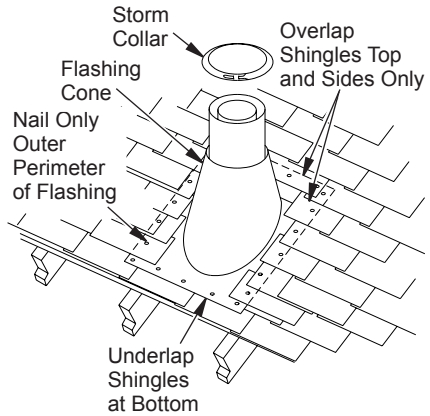

Figure 24 - Flashing Installation

STORM COLLAR INSTALLATION (SC-10)

Place storm collar over pipe and slide down until it is snug against the open edge of the flashing (see Figures 24 and 25). Apply waterproof caulking to all seams and notches around storm and also at base around shingles.

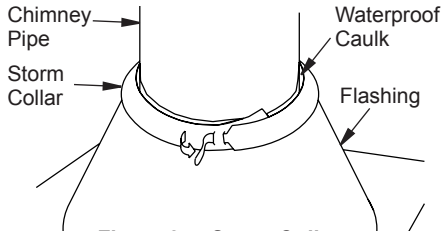

Figure 25 - Storm Collar

TERMINATIONS

The fireplace system must be terminated with the listed round top or chase terminations. In any case, refer to the installation instructions supplied with the termination.

Terminations approved for this fireplace are RLT-12D, which can be used for flashing or chase and STL-12D for chase style termination only. Figure 26, page 11, shows an RLT-12D round top termination.

⚠ CAUTION: Do not seal openings on the rooftop flashing. Follow the installation instructions provided with the termination being used.

VENTING INSTALLATION

Continued

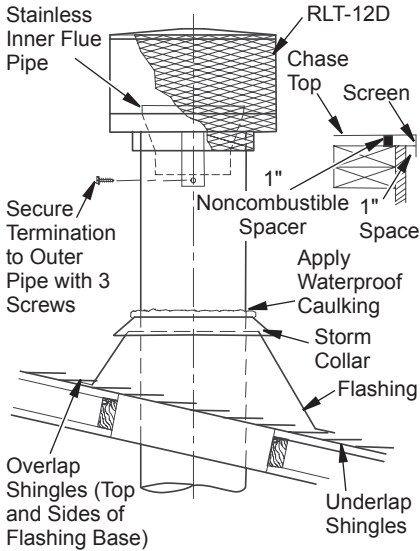

Figure 26 - Terminations

CHASE INSTALLATIONS

Instructions for chase installations are included with the chase style termination chosen. In a multiple chase installation, be sure to provide adequate distance between terminations to prevent smoke spillage from one termination to another. Terminations must be separated a minimum of 30" center to center and stacked at a minimum vertical height difference of 18" (see Figure 27).

Note: If a decorative shroud is to be installed, contact the manufacturer for specifications.

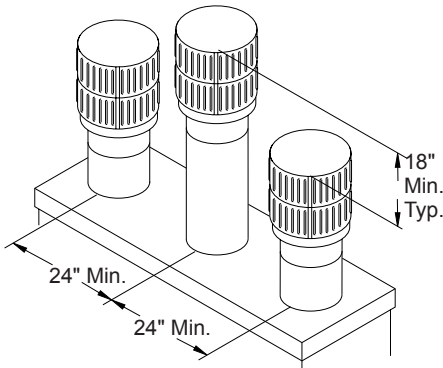

Figure 27 - Multiple Chase Installation

FINISHING FIREPLACE

Combustible materials, such as wallboard, gypsum board, sheet rock, drywall, plywood, etc. may make direct contact with sides and top around the fireplace face. It is important that combustible materials do not overlap the face itself. Brick, glass, tile or other noncombustible materials may overlap the front face provided they do not obstruct essential openings like louvered slots or any other opening. When overlapping with a noncombustible facing material, use only noncombustible facing material, use only noncombustible mortar or adhesive.

INSTALLING FIREPLACE FACING

Any noncombustible material may be used for facing (glass, tile, brick, etc.) as long as proper clearances are not obstructed in any way (see Minimum Clearance to Combustibles, page 4 and Figure 28).

Use only heat resistant, noncombustible mortar or adhesive when securing facing material to front of fireplace. When placing facing at upper edge of effective opening of fireplace, provide "L" shaped piece of metal extending full width of opening (see Figure 28).

Secure with sheet metal screws at a distance high enough from edge so it doesn't interfere with operation of doors. This assures that facing material will not block openings.

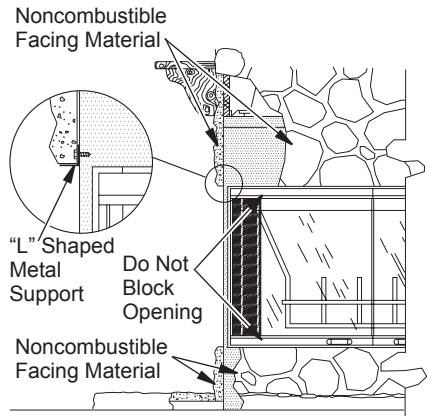

Figure 28 - Fireplace Facing (Your Fireplace May Vary from Illustration)

OPTIONAL GAS LINE INSTALLATION

⚠ WARNING: A qualified service person must connect fireplace to gas supply. Follow all local codes.

NOTICE: Before you proceed, make sure your gas supply is turned off.

A gas line may be installed for the purpose of installing a vented or vent-free decorative gas appliance available through your local distributor. Use only gas piping approved by local codes. When installing a gas line, a shutoff valve designed for installation outside the appliance is recommended.

The gas pipe is intended for connection to a decorative gas appliance that operates using natural or propane/LP gas only. This appliance must have an automatic shutoff device and must comply with the *Standard for Decorative Gas Appliances for Installation in Vented Fireplace, ANSI Z21.60*. ONLY UNVENTED GAS LOG SETS WHICH HAVE BEEN FOUND TO COMPLY WITH THE STANDARD FOR UNVENTED ROOM HEATERS, ANSI Z21.11.2, ARE TO BE INSTALLED IN THIS FIREPLACE.

Use only a 1/2" black iron pipe and appropriate fittings.

1. Remove knockout indentation on refractory or firebrick wall located approximately 2" above the refractory hearth floor. The knockout indentation must be firmly tapped with any solid object such as a 1/2" dowel until it is released. Remove fragmented portions of refractory (see Figure 29).
2. Remove gas line cover plate located on rear of fireplace and pull out insulation from gas line conduit sleeve. Save insulation for reuse.
3. Run gas line into the fireplace through the rear at 11 1/4" from floor and through gas line conduit sleeve (if using a raised platform, add height). Provide sufficient gas line into fireplace chamber for fitting connection (see Figure 30).

Note: Secure incoming gas line to wood framing to provide rigidity for threaded end.

4. Repack insulation around gas line and into sleeve opening. Seal any gaps between gas line and refractory knockout hole with

refractory cement or commercial furnace cement. Install the gas appliance or cap off gas line if desired.

⚠ CAUTION: All gas piping and connections must be tested for leaks after the installation is completed. After ensuring that the gas valve is on, apply soap and water solution to all connections and joints. Bubbles forming show a leak. Correct all leaks at once. DO NOT USE AN OPEN FLAME FOR LEAK TESTING AND DO NOT OPERATE ANY APPLIANCE IF A LEAK IS DETECTED. LEAK TESTING SHOULD BE DONE BY A QUALIFIED SERVICE PERSON.

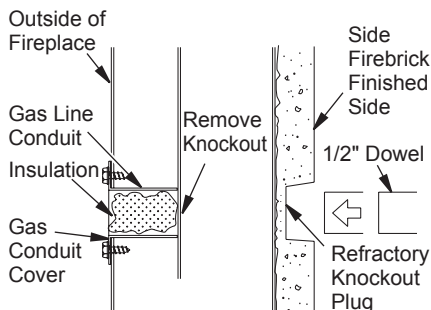

Figure 29 - Gas Line Knockout

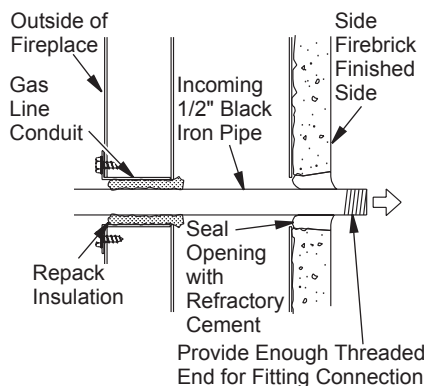

Figure 30 - Gas Line Installation

OPTIONAL GAS LINE INSTALLATION

Continued

⚠ WARNING: Do not operate an unvented gas log set in this fireplace with the chimney removed.

⚠ WARNING: If the fireplace has been used for wood burning, the firebox and chimney must be cleaned of soot, creosote and ashes by a qualified chimney cleaner. Creosote will ignite if heavily heated.

⚠ WARNING: When using a decorative vented gas log, the damper must be removed or permanently locked in the fully open position and the glass doors must be in the fully open position.

Note: An appropriate FMI PRODUCTS, LLC hood (see Replacement and Accessory Parts, page 15) must be installed when using an unvented gas log set.

OPERATION AND MAINTENANCE GUIDELINES

GLASS DOORS

Bi-fold glass doors are optional with this fireplace. Check with your local distributor for availability.

To install glass doors, refer to installation instructions that are included with kit. When fireplace is in operation, doors must be fully open or fully closed position only or a fire hazard may be created (see Figure 31).

A fireplace equipped with glass doors operates much differently than a fireplace with an open front. A fireplace with glass doors has a limited amount of air for combustion. Excessive heat within the fireplace can result if too large a fire is built or if combustion air gate is not completely open.

The following tips should be followed to assure that both the fireplace and glass door retain their beauty and function properly.

- Both the flue damper and glass doors must be fully opened before starting fire. This will provide sufficient combustion air and maintain safe temperatures in firebox.
- The glass must be allowed to warm slowly and evenly. The tempered glass will withstand a gradual temperature rise to 550° F, which is more than a normal fire will generate. Such materials as pitch/wax laden logs, very dry mill end lumber and large amounts of paper or cardboard boxes. Always keep the fire well back from the doors and never allow flames to contact the glass.

⚠ WARNING: Fireplaces equipped with glass doors should be operated only with doors fully opened or doors fully closed. Doors, if left partly open, may draw gas and flame out of the fireplace opening creating risks of both fire and smoke.

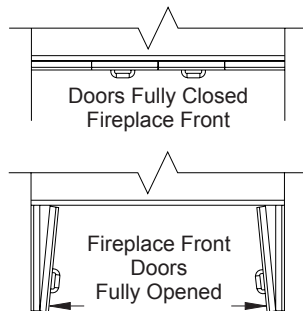

Figure 31 - Bi-Fold Glass Doors

Cleaning Glass

Clean glass with any commercial glass cleaner or soap and water. Do not use any abrasive material to clean glass. Do not clean glass with any cool water if glass is still hot from the fire. To remove doors, refer to instructions included with glass door kit.

OPERATION AND MAINTENANCE GUIDELINES

Continued

DAMPER MECHANISM

The damper control lever is located inside the fire chamber (see Figure 32). Make sure lever is cool before handling. Pull down to close and push up to open. Damper must be open when lighting a fire. Not doing so will cause smoke spillage into the room. When fireplace is not in use, close damper to prevent down drafts to enter room.

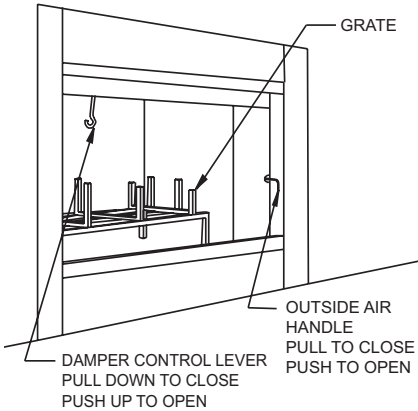

Figure 32 - Damper Operation

OUTSIDE AIR MECHANISM

The outside air handle is located at the right hand side of fireplace rear refractory (see Figure 32). Pull to close, push to open. Always

open mechanism when starting a fire. This provides adequate outside combustion air. Close mechanism when not in use to prevent cold air from entering room. Periodically check your outside air intake vent hood for any possible obstructions such as snow, bushes, etc.

GRATE

The grate is designed to provide you with the maximum solid fuel capacity. Do not overload grate or obstruct required air space beneath it. Doing so may cause smoke spillage and a fire hazard.

⚠ WARNING: Risk of fire! Replace grate with FMI PRODUCTS, LLC model 11169 grate only. This grate has been designed to keep the operation of your fireplace safe and efficient.

Never obstruct flow of combustion and ventilation air. Keep front of fireplace clear of all obstacles and materials.

CHIMNEY

Have your chimney system cleaned and inspected regularly to ensure safe and efficient operation.

TECHNICAL SERVICE

You may have further questions about installation, operation, or troubleshooting. If so, contact FMI PRODUCTS, LLC at 1-866-328-4537. When calling please have your model and serial numbers of your heater ready.

You can also visit our web site at www.fmiproducts.com.

REPLACEMENT AND ACCESSORY PARTS

ADJUSTABLE HOOD

Black - GA6050
Brass - GA6053

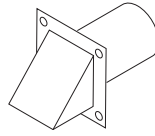
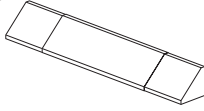

Vent Hood

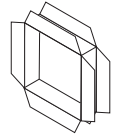

Vent Plaster Collar

GRATE, 10"
11169

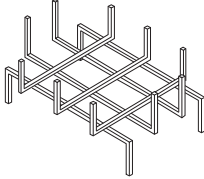

Connector
Duct - 4" x 3'

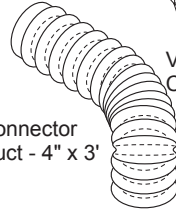

EMBER
PROTECTORS
20093

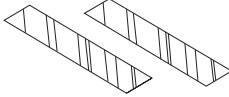

OUTSIDE AIR KIT - AK4

STORM COLLAR - SC2-1



FIRESTOP SPACER

FS-10 for Straight Pipe
30FS-10 for 30° Angled
Run

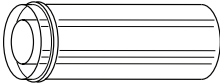
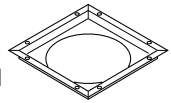

DOUBLE WALL PIPE - 12-12DM,
18-12DM, 24-12DM, 36-12DM, 48-12DM

(Chimney pipe assembly includes outer
and inner pipes and comes with wire
spacer. Also available in triple wall.)

FLASHING

V6F-10DM 0 to 6/12
Pitch
V12F-10DM 6/12 to
12/12 Pitch

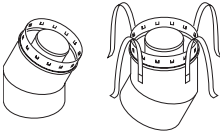
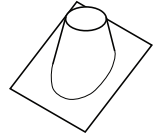

DOUBLE WALL 30° ELBOW/OFFSET
30E-12DM (Also available in triple wall.)

Round Top Termination
RLT-12D

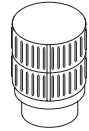

DOUBLE WALL PIPE
SUPPORT ASSEMBLY
12S-12DM (Also available
in triple wall.)

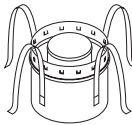

Econo Top Termination
STL-12D



Bi-Fold Glass Doors

DG368ST - Brushed
Brass

DBP368ST - Black with
Brass Trim

DC368ST - Platinum

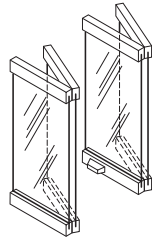

FMI PRODUCTS, LLC
2701 S. Harbor Blvd.
Santa Ana, CA 92704
1-866-328-4537
www.fmiproducts.com

115603-01
Rev. E
01/11