

INSTALLER: LEAVE THIS MANUAL WITH THE APPLIANCE.
CONSUMER: RETAIN THIS MANUAL FOR FUTURE REFERENCE.



INSTALLATION AND OPERATING INSTRUCTIONS

CERTIFIED UNDER U.S. ENVIRONMENTAL PROTECTION AGENCY (E.P.A.) JULY 1990 40 C.F. R. PART 60 AND THE OREGON DEPARTMENT OF ENVIRONMENTAL QUALITY (D.E.Q.) PARTICULATE EMISSION STANDARDS BY E.E.M.C THESE STOVES HAVE BEEN TESTED AND LISTED BY INTERTEK TESTING SERVICES TO STANDARDS: CSA B366.2, ULC S627, M2000 UL 1482. MODEL 1100 HAS BEEN TESTED AND LISTED FOR INSTALLATION IN MOBILE HOMES.

EPI 1101 & 1402 WOOD INSERT

SAFETY INFORMATION

WARNING

If the information in these instructions is not followed exactly, a fire or explosion may result causing property damage, personal injury or death. Improper installation, adjustment, alteration, service or maintenance can cause injury or property damage, bodily injury or even death. Please read entire manual before you install and use your appliance.

This appliance has not been tested with an unvented gas log set. To reduce risk of fire or injury, do not install an unvented gas log set into the appliance.

- This appliance can be very hot when burning.
- Combustible materials such as firewood, wet clothing, etc. placed too close can catch fire.
- Children and pets must be kept from touching the appliance when it is hot.
- The chimney must be sound and free of cracks. Before installing this unit, contact the local building or fire authority and follow their guidelines.
- Operate only with the door tightly closed.
- Burn wood behind the log retainer directly on the firebricks.
- Do not use an elevated grate or otherwise raise the fire.
- At least 14 square inches of outside air must be admitted to the room or directly to the unit through a 4" diameter pipe.
- This appliance is designed to burn natural wood only. Higher efficiencies and lower emissions generally result when burning air dried seasoned hardwoods, as compared to softwoods or to green or freshly cut hardwoods.
- Do not start a fire with chemicals or fluids such as gasoline, engine oil, etc.
- Do not burn treated wood, coal, charcoal, colored paper, cardboard, solvents or garbage.
- Do not let the appliance become hot enough for any part to glow red.
- KEEP THE STOVE TOP TEMPERATURE BELOW 700°F (371°C). Attempts to achieve heat output rates that exceed design specifications can result in steel distortion and damage.

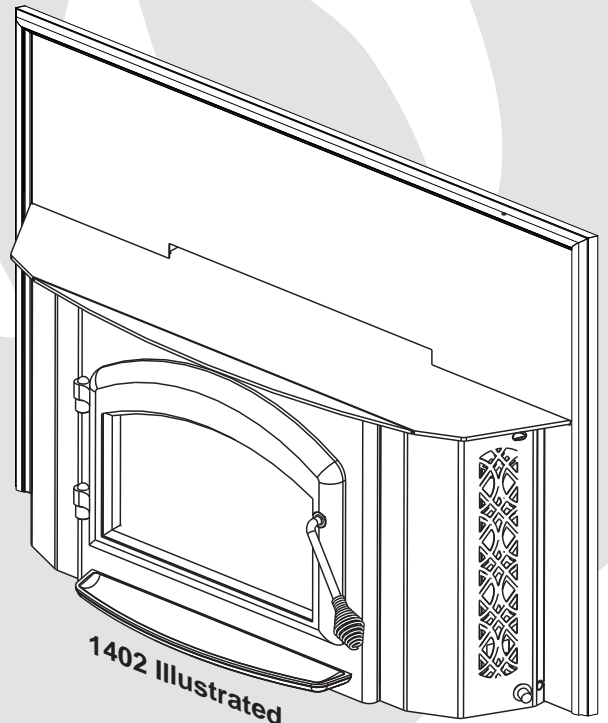

APPLY SERIAL NUMBER LABEL FROM CARTON



Serial No. XXXXX00000
MODEL NO.

Wolf Steel Ltd., 24 Napoleon Rd., Barrie, ON, L4M 4Y8 Canada /
103 Miller Drive, Crittenden, Kentucky, USA, 41030

Phone (705)721-1212 • Fax (705)722-6031 • www.napoleonfireplaces.com • ask@napoleonproducts.com

TABLE OF CONTENTS

1.0	INSTALLATION OVERVIEW	3
2.0	INTRODUCTION	4
2.1	DIMENSIONS	5
2.1.1	1101 DIMENSIONS (COMPLETE WITH FLASHING)	5
2.1.2	1402 DIMENSIONS (COMPLETE WITH FLASHING)	5
2.2	SPECIFICATIONS	5
2.3	GENERAL INSTRUCTIONS	6
2.4	GENERAL INFORMATION	6
2.5	RATING PLATE INFORMATION	8
3.0	INSTALLATION PLANNING	9
3.1	MINIMUM CLEARANCE TO COMBUSTIBLES	9
4.0	INSTALLATION	10
4.0.1	TYPICAL EXISTING MASONRY	11
4.0.2	FACTORY BUILT FIREPLACE	12
4.1	LOW CLEARANCE FLUE CONNECTOR (1402)	12
5.0	FINISHING	13
5.1	BRICKS AND BAFFLES INSTALLATION	13
5.2	DOOR REMOVAL / INSTALLATION	14
5.3	DOOR HANDLE INSTALLATION	14
5.4	FLASHING INSTALLATION	15
6.0	OPERATION	16
6.1	BLOWER	17
6.2	AIR CONTROL	18
6.3	FIRE EXTINGUISHERS / SMOKE DETECTORS	18
6.4	FUEL	18
6.5	LIGHTING A FIRE	19
6.5.1	FLASH FIRE	19
6.5.2	EXTENDED FIRE	19
6.6	SMOKING	19
8.0	MAINTENANCE	20
7.1	ASH REMOVAL PROCEDURES	20
7.2	CREOSOTE FORMATION AND REMOVAL	20
7.3	RUNAWAY OR CHIMNEY FIRE	21
7.4	CHIMNEY CLEANING	21
7.5	GLASS REPLACEMENT	22
7.6	GASKET REPLACEMENT	22
7.7	CARE OF GLASS	23
7.8	CARE OF PLATED PARTS	23
7.9	BLOWER SERVICE OR REPLACEMENT (1101)	24
7.10	BLOWER SERVICE OR REPLACEMENT (1402)	24
9.0	REPLACEMENTS	26
10.0	TROUBLE SHOOTING	28
11.0	WARRANTY	29
12.0	SERVICE HISTORY	30
13.0	NOTES	31

NOTE: Changes, other than editorial, are denoted by a vertical line in the margin.

1.0 INSTALLATION OVERVIEW

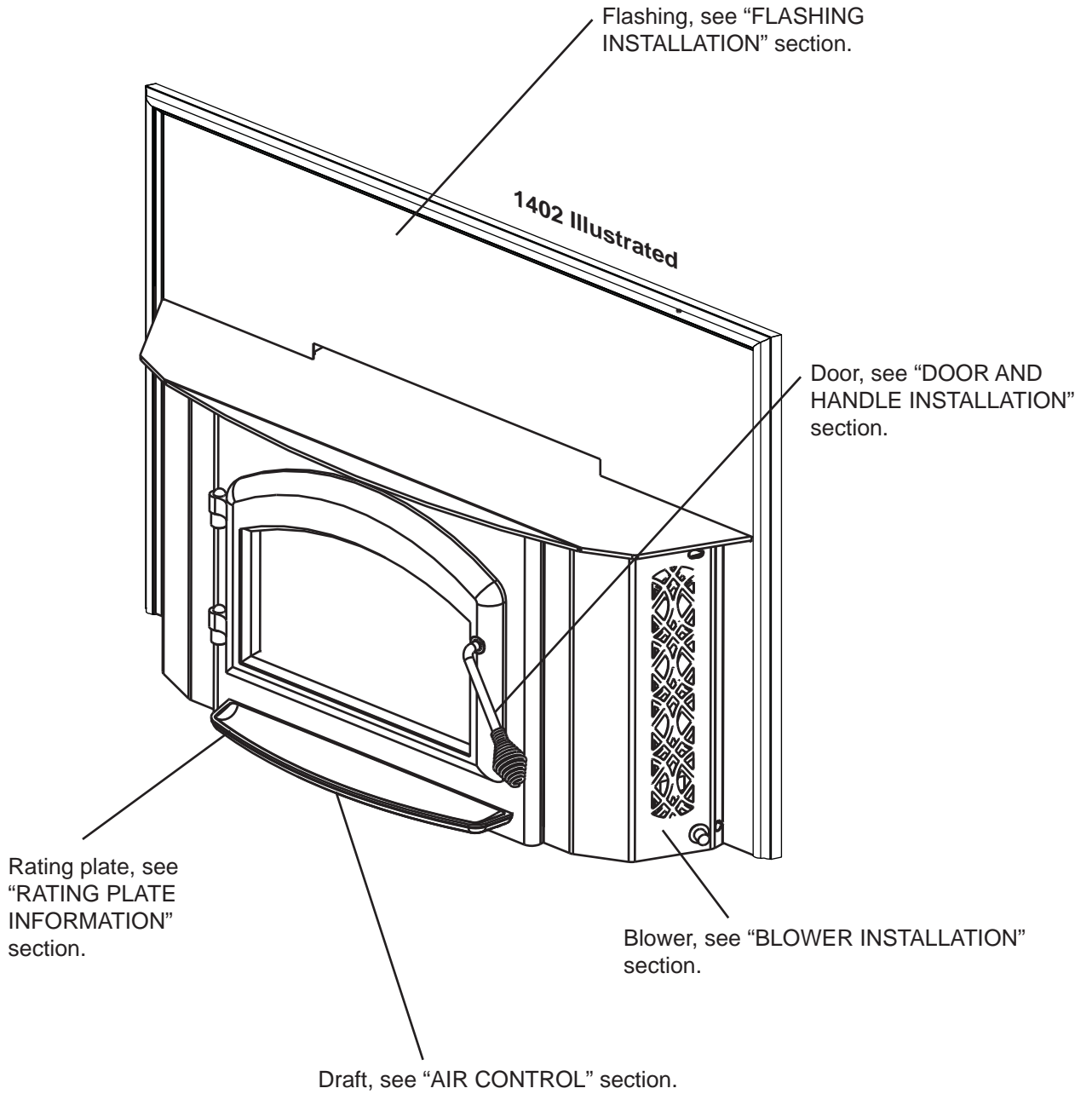

2.0 INTRODUCTION

WARNING

- **THIS APPLIANCE IS HOT WHEN OPERATED AND CAN CAUSE SEVERE BURNS IF CONTACTED.**
- **ANY CHANGES OR ALTERATIONS TO THIS APPLIANCE OR ITS CONTROLS CAN BE DANGEROUS AND IS PROHIBITED.**
- Do not operate appliance before reading and understanding operating instructions. Failure to operate appliance according to operating instructions could cause fire or injury.
- Before installing this appliance, contact the local building or fire authority and follow their guidelines.
- This appliance must be installed by a qualified installer.
- Risk of burns. The appliance should be turned off and cooled before servicing.
- Do not let the appliance become hot enough for any part to glow red.
- Do not install damaged, incomplete or substitute components.
- Risk of cuts and abrasions. Wear protective gloves and safety glasses during installation. Sheet metal edges may be sharp.
- Children and adults should be alerted to the hazards of high surface temperature and should stay away to avoid burns or clothing ignition.
- Young children should be carefully supervised when they are in the same room as the appliance. Toddlers, young children and others may be susceptible to accidental contact burns. A physical barrier is recommended if there are at risk individuals in the house. To restrict access to an appliance or stove, install an adjustable safety gate to keep toddlers, young children and other at risk individuals out of the room and away from hot surfaces.
- Clothing or other flammable material should not be placed on or near the appliance. Objects placed in front of the appliance must be kept a minimum of 48" away from the front face of the appliance.
- Due to high temperatures, the appliance should be located out of traffic and away from furniture and draperies.
- Ensure you have incorporated adequate safety measure to protect infants/toddlers from touching hot surfaces.
- Even after the appliance is out, the glass and/or screen will remain hot for an extended period of time.
- Check with your local hearth specialty dealer for safety screens and hearth guards to protect children from hot surfaces. These screens and guards must be fastened to the floor.
- Any safety screen or guard removed for servicing must be replaced prior to operating the appliance.
- Under no circumstances should this appliance be modified.
- This appliance must not be connected to a chimney flue pipe servicing a separate solid fuel burning appliance.
- Do not operate the appliance with the glass door removed, cracked or broken. Replacement of the glass should be done by a licensed or qualified service person.
- Do not strike or slam shut the appliance glass door.
- Operate only with the doors tightly closed.
- Only doors / optional fronts certified with the unit are to be installed on the appliance.
- Keep the packaging material out of reach of children and dispose of the material in a safe manner. As with all plastic bags, these are not toys and should be kept away from children and infants.
- If the appliance is not properly installed, a house fire may result. Do not expose the appliance to the elements (ex. rain, etc.) and keep the appliance dry at all times. Wet insulation will produce an odour when the appliance is used.
- The chimney must be sound and free of cracks. Clean your chimney a minimum of twice a year and as required.
- Do not start a fire with chemicals or fluids such as gasoline, engine oil, etc.
- Your appliance requires periodic maintenance and cleaning. Failure to maintain your appliance may lead to smoke spillage in your home.
- Higher efficiencies and lower emissions generally result when burning air dried seasoned hardwoods, as compared to softwoods or too green or freshly cut hardwoods. Burning wet unseasoned wood can cause excessive creosote accumulation. When this is ignited it can cause a chimney fire that may result in a serious house fire.
- This appliance is designed to burn natural wood only. Do not burn treated wood, coal, charcoal, coloured paper, cardboard, solvents or garbage.
- Burn wood directly on the firebricks. Do not elevate grate or otherwise raise the fire.
- Do not store wood within appliance installation clearances or within the space required for re-fueling and ash removal.
- Ashes must be disposed in a metal container with a tight lid and placed on a non-combustible surface well away from the home or structure until completely cool.
- Ensure clearances to combustibles are maintained when building a mantel or shelves above the appliance. Elevated temperatures on the wall or in the air above the appliance can cause melting, discolouration or damage to decorations, a T.V. or other electronic components.

3.17C

2.12.1 DIMENSIONS

2.1.1 1101 DIMENSIONS (COMPLETE WITH FLASHING)

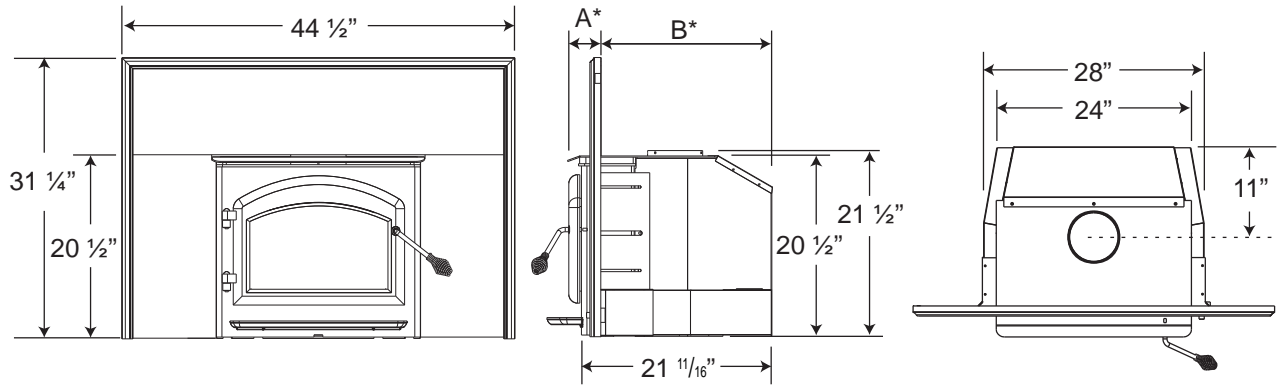

2.1.2 1402 DIMENSIONS (COMPLETE WITH FLASHING)

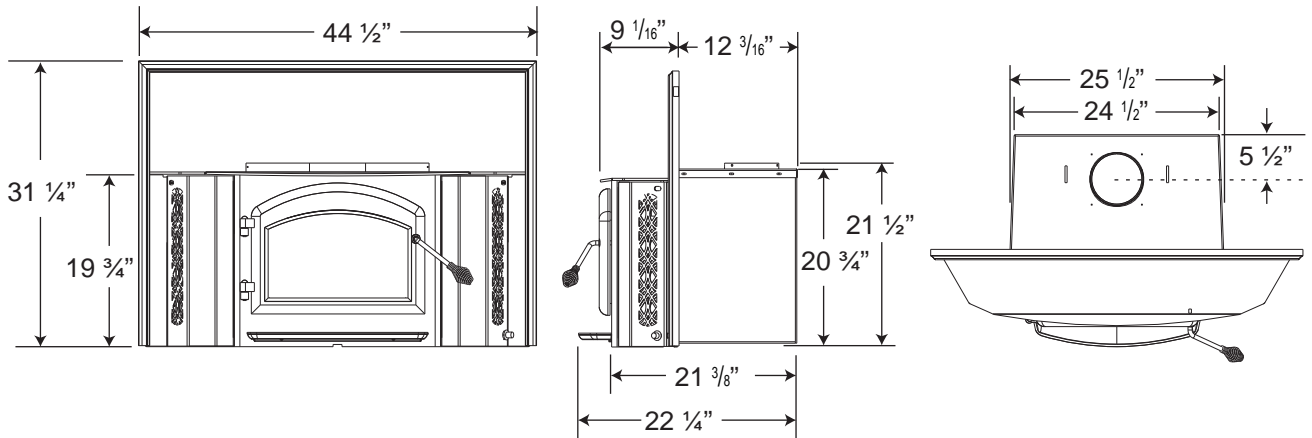

2.2 SPECIFICATIONS

Specifications	1101		1402
CHAMBER (D.W.H)	13 1/2x18x12"		18x18x12"
CAPACITY	1.7 ft ³		2.25 ft ³
APPROX. AREA HEATED*	600-1600 ft ²		800-2000 ft ²
HEAT OUTPUT (HIGH BURN) **	55,000 BTU		70,000 BTU
DURATION LOW FIRE*	7 Hours		9 Hours
WEIGHT W/O BRICKS	185 lbs		250 lbs
WEIGHT OF BRICKS	110 lbs		145 lbs
IDEAL FUEL SIZE	12"		16"
	A	B	N/A
MIN DEPTH	7 3/4"	15 5/8"	
MAX DEPTH	3 3/4"	19 5/8"	

* Figures will vary considerably with individual conditions.

** Wolf Steel Ltd. estimated realistic BTU/h with hardwood logs and regular refueling.

2.3 GENERAL INSTRUCTIONS

 WARNING
ALL WIRING SHOULD BE DONE BY A QUALIFIED ELECTRICIAN AND SHALL BE IN COMPLIANCE WITH LOCAL CODES. IN THE ABSENCE OF LOCAL CODES, USE THE CURRENT CSA22.1 CANADIAN ELECTRIC CODE IN CANADA OR THE CURRENT NATIONAL ELECTRIC CODE ANSI/NFPA NO. 70 IN THE UNITED STATES.
THIS APPLIANCE HAS NOT BEEN TESTED WITH ANY VENTED OR UNVENTED GAS LOG SET. TO REDUCE RISK OF FIRE OR PREVENT INJURY, DO NOT INSTALL A VENTED OR UNVENTED GAS LOG SET INTO THE APPLIANCE.
BURNING YOUR UNIT WITH THE ASH DUMP DOOR OPEN OR AJAR CREATES A FIRE HAZARD THAT MAY RESULT IN DISCOLOURATION TO THE GOLD PLATED DOOR, INTERNAL DAMAGE TO THE APPLIANCE OR A HOUSE CHIMNEY FIRE.
DO NOT CONNECT THIS APPLIANCE TO A CHIMNEY FLUE SERVING ANOTHER APPLIANCE.
THIS APPLIANCE AND IT'S COMPONENTS ARE DESIGNED TO BE INSTALLED AND OPERATED AS A SYSTEM. ANY ALTERATION TO OR SUBSTITUTION FOR ITEMS IN THIS SYSTEM, UNLESS ALLOWED BY THESE INSTALLATION INSTRUCTIONS, WILL VOID THE LISTING AND MAY VOID THE PRODUCT WARRANTY. IT MAY ALSO CREATE A HAZARDOUS INSTALLATION. READ THROUGH THESE INSTRUCTIONS THOROUGHLY BEFORE STARTING YOUR INSTALLATION AND FOLLOW THEM CAREFULLY THROUGHOUT YOUR PROJECT.

4.7

- Before beginning your installation, consult with your local building code agency or fire officials and insurance representative to ensure compliance.
- Non-toxic smoke will be emitted during the paint curing process, to help dissipate the smoke open a window near the appliance.
- Remove any dust or debris off the top of the appliance before firing the appliance as the paint will become soft as the appliance heats up and will harden as the appliance cures. To cure the paint on your appliance burn your appliance moderately hot during the first few fires.
- To keep the gasket from sticking to the appliance as the paint is curing, periodically open the door every 5-10 minutes.
- For the first two weeks use generous amounts of fuel and burn the appliance with the damper wide open for an hour as the appliance goes through a process of eliminating moisture in the steel and fire-bricks. The initial heat output will be reduced while the moisture is being drawn from the appliance and it will be necessary to build several hot fires to remove this moisture. **DURING THIS PROCESS DO NOT OVERFIRE THE APPLIANCE. REDUCE THE AMOUNT OF AIR COMING INTO THE APPLIANCE IF THE APPLIANCE OR CHIMNEY BECOMES RED.**

2.4 GENERAL INFORMATION

Your appliance was specifically designed to meet the 1990 U.S.A. EPA particulate emission standards and has been extensively tested in Canadian and American laboratories. This system is the most efficient, simple and trouble free we know and works as follows:

Your appliance is the exact duplication of the clean-burning technology found in all Napoleon EPA certified freestanding stoves and in particular that of the EPA 1100 and 1400. External modifications have been made to allow its installation as a "functional insert" with a heat circulating blower system and a means of enclosing the solid fuel burning fireplace cavity for greater heating efficiency.

The 1101 insert must be installed into a solid fuel burning fireplace that is at least 16 1/2 inches deep, 28 1/2 inches wide and 22 inches high with an approved lined chimney at least 15 feet high (4.6m) and a hearth of 16”.

Your 1402 insert must be installed only into a solid fuel burning fireplace that is at least 14 inches deep 26 inches wide and 22 inches high with an approved lined chimney at least 15 feet high (4.6m) and a hearth of 16”. This minimum recess can only be achieved if the opening height is sufficient enough to allow the connector to fit under the noncombustible facing. The appliance and chimney must be constructed in accordance with all national and local building code standards.

The chimney vent system used on your wood burning appliance should be designed with the least amount of restriction possible to enable the exhaust products to easily flow through it. Chimney vent systems that are too short or too long can also have an adverse affect on the flow of exhaust through it. The wood burning appliance and chimney vent system also require a sufficient supply of combustion air not only to support the combustion in the combustion chamber but to replace the exhaust leaving it so it can flow freely up through the vent system and out into the atmosphere. It is the correct balance of combustion air and the chimney vent system that will ensure the appliance provides you with its optimum performance.

Combustion air enters through two holes in the bottom covered by a single draft control. Air from the front hole goes up on either side of the door into a preheating airwash located across the top and then down the window to feed the fire and also to ensure that the glass remains clean. Air from this hole also feeds directly into the combustion chamber at hearth level. Secondary air from the rear hole travels up the back in the secondary air housing to the manifold located at the top and shoots out laterally to oxidize the gases below the smoke exit. The combustion chamber is lined with high temperature firebrick on 2 sides, the back and across the bottom, with a layer of fibre baffles at the top to maintain a high temperature in the combustion chamber so that gases mixing with the preheated air from the secondary air manifold tube are easily ignited and burned. The appliance sides and back are shielded to direct the heat upwards and forwards into the room.

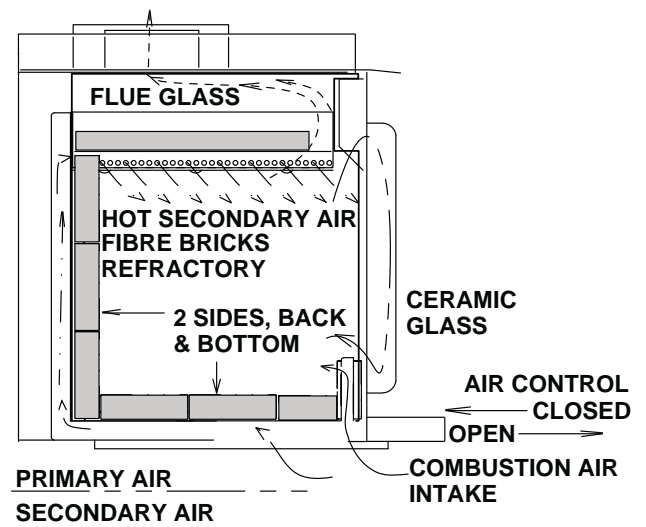

Be sure to provide sufficient combustion air. There are many other appliances in your home competing for air such as: a kitchen range hood, forced air heating devices or a bathroom exhaust fan.

Expansion / contraction noises during heating up and cooling down cycles are normal and to be expected.

After extended periods of non-operation such as following a vacation or a warm weather season, the appliance may emit a slight odour for a few hours. This is caused by dust particles on the firebox burning off. Open a window to sufficiently ventilate the room.

CALIFORNIA PROP 65 WARNING:

Use of this product may produce smoke which contains chemicals known to the State of California to cause cancer, birth defects, or other reproductive harm.

If you experience smoking problems, you may need to open a door, a window or otherwise provide some method of supplying combustion air to the appliance.

HINT FOR INSTALLING PORCELAIN ENAMEL INSERTS:

Ensure the base of the porcelain side panels are protected from rubbing against the hearth when sliding your insert into the masonry fireplace.

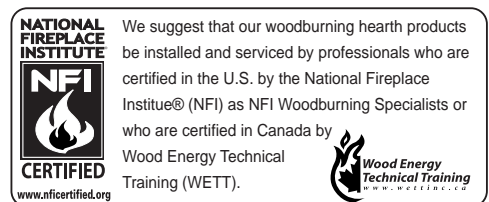





2.5 RATING PLATE INFORMATION

For rating plate location, see "INSTALLATION OVERVIEW" section.

This illustration is for reference only. Refer to the rating plate on the appliance for accurate information.



LISTED SOLID FUEL BURNING SPACE HEATER / POÊLE À COMBUSTIBLE SOLIDE HOMOLOGUÉ
TESTED TO: / TESTÉ SELON: UL1482 / ULC S627 / CSA B366.2 (DEC 92)
MODEL / MODÈLE - EPA 1400

INSTALL AND USE ONLY IN ACCORDANCE WITH THE MANUFACTURER'S INSTRUCTIONS AND LOCAL BUILDING CODES.
 MINIMUM CEILING HEIGHT: 7FT (2.13m)

HEARTH EXTENSION / COMBUSTIBLE FLOOR PROTECTION: IF INSTALLED ON A COMBUSTIBLE FLOOR, UNIT MUST BE PLACED ON A NON-COMBUSTIBLE FLOOR PROTECTOR EXTENDING 18" (455mm) IN FRONT AND 8" (205mm) TO THE SIDES AND BACK.

CHIMNEY TYPE: MINIMUM 6" (152mm) DIAMETER APPROVED RESIDENTIAL TYPE FOR MOBILE HOME USE A CHIMNEY LISTED TO ULC S629 IN CANADA OR UL 103HT IN THE USA.

CHIMNEY CONNECTOR: 6" (152mm) DIAMETER MINIMUM 24 GAUGE STEEL MINIMUM CLEARANCE FROM HORIZONTAL CONNECTOR AND CEILING 18" (455mm). DO NOT OBSTRUCT SPACE UNDER HEATER. SPECIAL METHODS ARE REQUIRED WHEN PASSING A CHIMNEY THROUGH A WALL OR CEILING. SEE INSTRUCTIONS AND BUILDING CODES.

DO NOT CONNECT THIS UNIT TO A CHIMNEY FLUE SERVING ANOTHER APPLIANCE.

FUEL: FOR USE WITH WOOD ONLY. DO NOT USE GRATE OR ELEVATE FIRE. BUILD WOOD FIRE DIRECTLY ON HEARTH.

WARNING: RISK OF SMOKE SPILLAGE. OPERATE ONLY WITH DOOR FULLY CLOSED. REPLACE GLASS ONLY WITH CERAMIC GLASS. DO NOT OVERFIRE. IF HEATER OR CHIMNEY CONNECTORS GLOW, YOU ARE OVERFIRING. INSPECT AND CLEAN CHIMNEY FREQUENTLY. UNDER CERTAIN CONDITIONS OF USE CREOSOTE BUILD-UP MAY OCCUR RAPIDLY.

OPTIONAL BLOWER KIT: EP-62, 115V, 60HZ, 0.82AMP. ROUTE CORD AWAY FROM UNIT.

DANGER: RISK OF ELECTRICAL SHOCK. DISCONNECT POWER BEFORE SERVICING UNIT.

INSERT: INSTALL AND USE ONLY IN SOLID FUEL BURNING FIREPLACES. DO NOT REMOVE BRICKS OR MORTAR FROM SOLID FUEL BURNING FIREPLACE. INSTALL WITH A POSITIVE FLUE CONNECTOR AND FACEPLATE.

POUR INSTALLATION ET UTILISATION CONFORMÉMENT AUX INSTRUCTIONS DU FABRICANT ET AUX CODES LOCAUX DU BÂTIMENT. HAUTEUR DE PLAFOND MINIMAL 7PI (2,13m).

PROLONGEMENT D'ÂTRE/PROTECTION DU PLANCHER COMBUSTIBLE: SI INSTALLÉ SUR UN PLANCHER COMBUSTIBLE, L'APPAREIL DOIT ÊTRE PLACÉ SUR UNE PLAQUE PROTECTRICE INCOMBUSTIBLE S'ÉTENDANT SUR 18" (455mm) À L'AVANT ET 8" (205mm) À L'ARRIÈRE ET SUR LES CÔTÉS.

TYPE DE CHIMNÉE: DIAMÈTRE MINIMAL DE 6" (152mm) APPROUVÉE POUR USAGE RÉSIDENIEL MAISON MOBILE EMPLOYEZ UNE CHEMINÉE HOMOLOGUÉE ULC S629 AU CANADA OU UL 103HT AUX ÉTATS-UNIS.

RACCORD DE CHEMINÉE: DIAMÈTRE DE 6" (152mm) D'ACIER DE CALIBRE 24 MINIMUM. 18" (455mm) DE DÉGAGEMENT MINIMAL ENTRE LE RACCORD HORIZONTAL ET LE PLAFOND. NE RIEN ENTREPOSER SOUS L'APPAREIL. DES MÉTHODES SPÉCIALES SONT REQUISES LORSQU'UNE CHEMINÉE TRAVERSE UN MUR OU UN PLAFOND. VOIR LES INSTRUCTIONS ET LES CODES DU BÂTIMENT.

NE PAS RACCORDER À LA CHEMINÉE D'UN AUTRE APPAREIL COMBUSTIBLE. POUR USAGE AVEC LE BOIS SEULEMENT. N'UTILISEZ PAS DE CHENET OU NE SURÉLEVEZ PAS LE BOIS. PRÉPAREZ LE FEU DIRECTEMENT SUR L'ÂTRE!

AVERTISSEMENT: RISQUE D'ÉCHAPPEMENT DE FUMÉE. TENIR LA PORTÉ FERMÉE LORSQUE LE POÊLE FONCTIONNE. REMPLACEZ LA VITRE PAR UNE VITRE EN CÉRAMIQUE SEULEMENT. NE SURCHAUFFEZ PAS L'APPAREIL. SI L'APPAREIL OU LES RACCORDS ROUGE-OIENT, L'APPAREIL SURCHAUFFE. INSPECTEZ ET NETTOYEZ LA CHEMINÉE FRÉQUEMMENT. DANS CERTAINES CONDITIONS, DES DÉPÔTS DE CRÉOSOTE PEUVENT SE FORMER RAPIDEMENT.

SOUFFLERIE OPTIONNELLE: EP-62, 115V, 60HZ, 0,82A. TENEZ LE CORDON ÉLECTRIQUE LOIN DE L'APPAREIL.

DANGER: RISQUE DE SECOURS ÉLECTRIQUE. DÉBRANCHEZ AVANT DE PROCÉDER À L'ENTRETIEN.

ENCASTRÉ: INSTALLEZ ET UTILISEZ SEULEMENT DANS UN FOYER À COMBUSTIBLE SOLIDE. NE RETIREZ PAS DE MORTIER, NI BRIQUES DU FOYER À COMBUSTIBLE SOLIDE. INSTALLEZ AVEC UNE GAINE CONFORME ET UNE PLAQUE DE RECouvreMENT.

CONTACT LOCAL BUILDING FIRE OFFICIALS ABOUT RESTRICTIONS AND INSTALLATION INSPECTION IN YOUR AREA. MODEL 1400 IS SUITABLE FOR USE IN MOBILE HOMES WHEN USED WITH OUTSIDE AIR INSTALLATION KIT (111KT). A MINIMUM CLEARANCE OF 18" (457mm) TO THE CHIMNEY CONNECTOR MAY BE REQUIRED BY THE AUTHORITY HAVING JURISDICTION. RENSEIGNEZ-VOUS AUPRÈS DES AUTORITÉS LOCALES DU BÂTIMENT ET DU SERVICE DES INCENDIES AU SUJET DES RESTRICTIONS ET DES INSPECTIONS D'INSTALLATION DANS VOTRE RÉGION. LES MODÈLES 1400 PEUVENT ÊTRE INSTALLÉS DANS UNE MAISON MOBILE SI INSTALLÉS CONJOINTEMENT AVEC UNE PRISE D'AIR EXTÉRIEUR (111KT). UN DÉGAGEMENT MINIMAL DE 18" (457mm) JUSQU'AU RACCORD DE LA CHEMINÉE PEUT ÊTRE EXIGÉ PAR L'AUTORITÉ AYANT JURISDICTION.

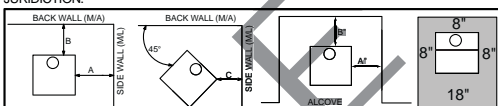

IF THE STOVE IS TO BE INSTALLED ON A COMBUSTIBLE FLOOR, IT MUST BE PLACED ON AN APPROVED NON-COMBUSTIBLE HEARTH PAD, THAT EXTENDS 8" (200mm) BEYOND THE STOVE SIDES AND BACK, AND 18" (455mm) TO THE FRONT.

SI LE POÊLE EST INSTALLÉ SUR UN PLANCHER COMBUSTIBLE, IL DOIT ÊTRE PLACÉ SUR UNE BASE DE PROTECTION INCOMBUSTIBLE CERTIFIÉE QUI DOIT DÉPASSER LES CÔTÉS ET L'ARRIÈRE DU POÊLE DE 8" (200mm) ET SE PROLONGER DE 18" (455mm) SUR LE DEVANT.

MINIMUM CLEARANCE TO COMBUSTIBLE MATERIAL WITH SINGLE WALL CHIMNEY CONNECTOR / DÉGAGEMENTS MINIMAUX AUX MATÉRIAUX COMBUSTIBLES AVEC RACCORD DE CHEMINÉE À PAROI SIMPLE:

FROM HEATER / DU POÊLE		RESIDENTIAL / RÉSIDENIEL	
1400	12IN/PO (305 mm)	1400	10IN/PO (254 mm)
1400L	12IN/PO (305 mm)	1400L	6IN/PO (152 mm)
1402	6IN/PO (152 mm)	1402	4IN/PO (102 mm)

USING DOUBLE WALL CONNECTOR/UTILISATION D'UN CONDUIT DE RACCORDEMENT À DOUBLE PAROI:

RESIDENTIAL / RÉSIDENIEL		MAISON / MOBILE HOME*	
1400	10IN/PO (254 mm)	1400	10IN/PO (254 mm)
1400L	6IN/PO (152 mm)	1400L	6IN/PO (152 mm)
1402	4IN/PO (102 mm)	1402	4IN/PO (102 mm)

*MODEL 1400 MAY MAY BE INSTALLED INTO A MOBILE HOME IN THE UNITED STATES ONLY.
 *LE MODÈLE 1400 NE PEUT ÊTRE INSTALLÉ QUE DANS UNE MAISON MOBILE AUX ÉTATS-UNIS SEULEMENT.

LISTED SOLID FUEL BURNING FIREPLACE INSERT / ENCASTRÉ À COMBUSTIBLE SOLIDE HOMOLOGUÉ
 TESTED TO: / TESTÉ SELON: ULC S628 / UL 1482 EPI 1402

CEILING / PLAFOND

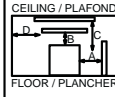

FLOOR / PLANCHER

CLEARANCES TO COMBUSTIBLE CONSTRUCTION / DÉGAGEMENTS AUX MATÉRIAUX COMBUSTIBLES: (MEASURED TO UNIT / À PARTIR DE L'APPAREIL):

A SIDE FACING / CÔTÉ	1 IN/PO (25mm)*
B TOP FACING / DESSUS	28 IN/PO (710mm)
C MANTEL / TABLETTE	28 IN/PO (710mm)
D SIDE WALL / MUR LATÉRAL	17 IN/PO (430mm)

*CLEARANCE TO EDGE OF FLASHING / DÉGAGEMENT AU BORD DE LA FAÇADE

CAUTION: HOT WHILE IN OPERATION. DO NOT TOUCH. KEEP CHILDREN, CLOTHING AND FURNITURE AWAY. CONTACT MAY CAUSE SKIN BURNS.

ATTENTION: QUAND L'APPAREIL FONCTIONNE, LA SURFACE DEVIENT CHAUDE. NE PAS TOUCHER. TENIR LES ENFANTS, LES VÊTEMENTS ET LES MEUBLES À L'ÉCART. LE CONTACT PEUT CAUSER DES BRÛLURES À LA PEAU.



WOLF STEEL LTD.
 24 Napoleon Rd. Barrie, Ontario L4M 4Y8 Canada ■
WOLF STEEL USA
 103 Miller Drive, Crittenden, Kentucky, USA, 41030 ■

U.S. ENVIRONMENTAL PROTECTION AGENCY Certifié conforme à la norme d'émission de particules de juillet 1992.

EPA1400

DATE CODE / DE DATE

W385-0401 / G

1400 SERIES RATING PLATE ILLUSTRATED

3.0 INSTALLATION PLANNING

Clean all ashes out of the inside of the existing fireplace opening. Make sure that the chimney and fireplace are free of cracks, loose mortar, creosote deposits, blockage or other signs of deterioration. If necessary, have any repair work done by a qualified professional before installing the insert.

Do **NOT** remove bricks or mortar from the fireplace. In case of an outside air inlet or ash dump, fill with fiber-glass insulation. Adhere to minimum clearances as illustrated.

Do **NOT** place any combustible materials (furniture, firewood, etc.) within 48" in front of 36" at the sides of the insert.

Combustible material must not protrude more than 1" to the side of the insert or between the mantel and the top of the insert.

3.1 MINIMUM CLEARANCE TO COMBUSTIBLES

MINIMUM CLEARANCES			
		1101	1402
A	Sidewall	17"	17"
B	Mantel	28"	28"
C	Top facing	28"	28"
D	Side facing	1"	1"
E	Hearth (front)	16"	16"
F	Hearth (side)	8"	8"
G	Objects in front of insert	48"	48"
MINIMUM FIREPLACE SIZE			
H	Width (rear)	24"	25"
I	Width (front)	28.5"	26"
J	Height (front)	22"	22"
K	Height (rear)	22"	22"
L	Depth	16 1/2" to 21"	14"
M	Hearth width	39"	39"
N	Facing width	46 1/2"	46 1/2"
O	Facing height	48 1/2"	47 3/4"
P	Mantel	48 1/2"	47 3/4"

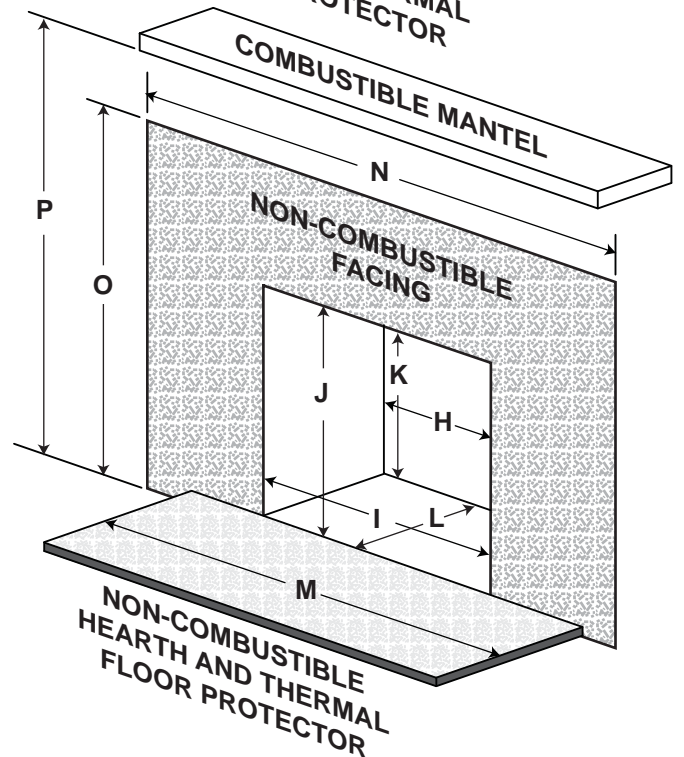
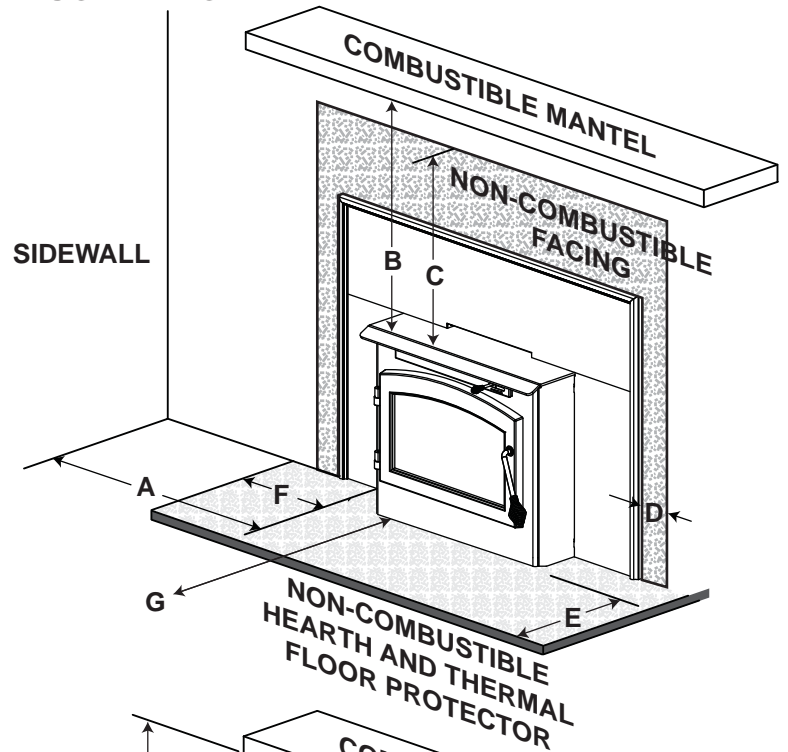

HEARTH EXTENSION / FLOOR PROTECTION:

Must be non-combustible and extend in front of the insert and 8" on both sides with a minimum thickness of .500" and a thermal conductivity factor (K) 0.84.

4.0 INSTALLATION

 WARNING
WEAR GLOVES AND SAFETY GLASSES FOR PROTECTION.
CAREFULLY FOLLOW THE INSTRUCTIONS FOR ASSEMBLY OF THE PIPE AND OTHER PARTS NEEDED TO INSTALL THE APPLIANCE. FAILURE TO DO SO MAY RESULT IN A FIRE, ESPECIALLY IF COMBUSTIBLES ARE TOO CLOSE TO THE APPLIANCE OR CHIMNEY AND AIR SPACES ARE BLOCKED, PREVENTING THE FREE MOVEMENT OF COOLING AIR.
DO NOT DRAW OUTSIDE AIR FROM GARAGE SPACES. EXHAUST PRODUCTS OF GASOLINE ENGINES ARE HAZARDOUS. DO NOT INSTALL OUTSIDE AIR DUCTS SUCH THAT THE AIR MAY BE DRAWN FROM ATTIC SPACES, BASEMENTS OR ABOVE THE ROOFING WHERE OTHER HEATING APPLIANCES OR FANS AND CHIMNEYS EXHAUST OR UTILIZE AIR. THESE PRECAUTIONS WILL REDUCE THE POSSIBILITY OF APPLIANCE SMOKING OR AIR FLOW REVERSAL. THE OUTSIDE AIR INLET MUST REMAIN CLEAR OF LEAVES, DEBRIS ICE AND/OR SNOW. IT MUST BE UNRESTRICTED WHILE APPLIANCE IS IN USE TO PREVENT ROOM AIR STARVATION WHICH CAN CAUSE SMOKE SPILLAGE AND AN INABILITY TO MAINTAIN A FIRE. SMOKE SPILLAGE CAN ALSO SET OFF SMOKE ALARMS.
NEGATIVE PRESSURE WITHIN YOUR HOME MAY INADVERTENTLY AFFECT YOUR APPLIANCE.
TO PREVENT CONTACT WITH SAGGING OR LOOSE INSULATION, THE APPLIANCE MUST NOT BE INSTALLED AGAINST VAPOUR BARRIERS OR EXPOSED INSULATION. LOCALIZED OVERHEATING COULD OCCUR AND A FIRE COULD RESULT.
DO NOT USE MAKESHIFT COMPROMISES DURING INSTALLATION. DO NOT BLOCK OR RESTRICT AIR, GRILLE OR LOUVRE OPENINGS. DO NOT ADD A HOOD.
KEEP HAND TOOLS IN GOOD CONDITION, SHARPEN CUTTING EDGES AND MAKE SURE TOOL HANDLES ARE SECURE.
ALWAYS MAINTAIN THE MINIMUM AIR SPACE REQUIRED TO THE ENCLOSURE TO PREVENT FIRES.

68.3A

Chimney and liner must be in good condition and kept clean.

4.0.1 TYPICAL EXISTING MASONRY

! WARNING

DO NOT CONNECT THIS APPLIANCE TO A CHIMNEY FLUE SERVING ANOTHER APPLIANCE. DO NOT CONNECT TO ANY AIR DISTRIBUTION DUCT OR SYSTEM.

You can install your appliance using your existing masonry chimney. To do so, follow the guidelines below. If you are using a masonry chimney, it is important that it be built in compliance with the specifications of the Building Code in your region. It must normally be lined with fire clay bricks, metal or clay tiles sealed together with fire cement. (Round flues are the most efficient).

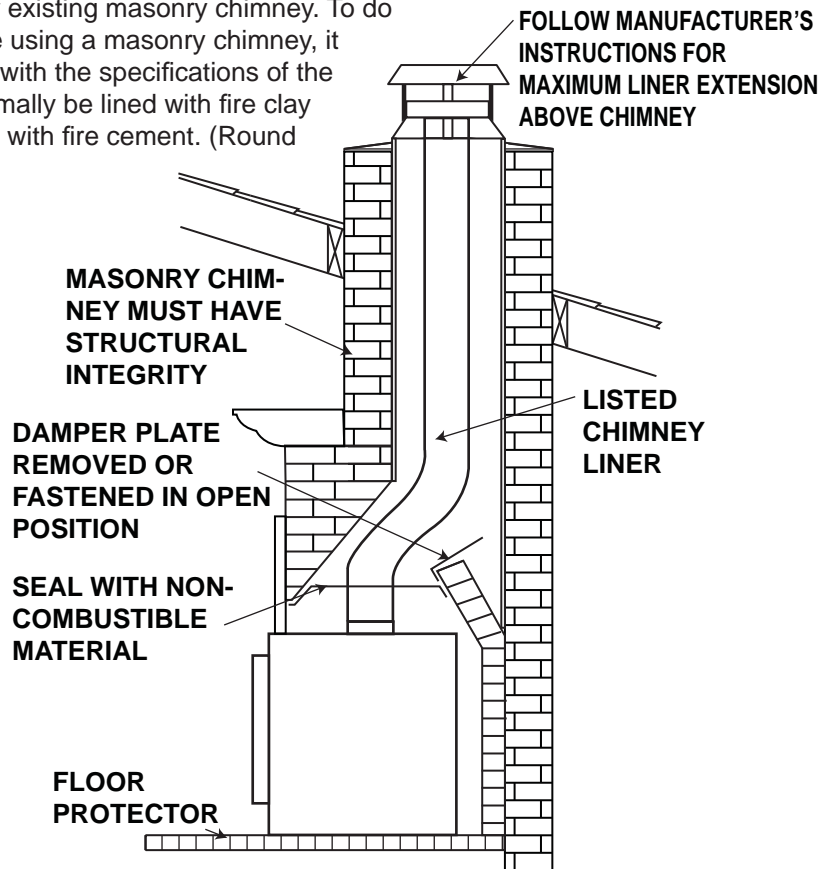

- A.** Remove the fireplace damper or fasten it permanently open.
* We recommend the following method of sealing off the damper area around the liner.
- B.** * Measure the throat of the fireplace and mark this shape on a piece of 24 gauge sheet metal (flue cover); cut a six-inch (6.75") hole to lie directly below the fireplace flue opening. Allow two inches of material for a flange on all sides and cut to these measurements. Bend down the flanges. If you have never done this before, it might be a good idea to make a cardboard pattern and test it first. Fasten this flue cover in position as high as possible with two masonry screws per side through the flanges into the fireplace.

In Canada: Install a listed 6 inch diameter flexible stainless steel liner from the top of the chimney to the insert flue collar. Attach a stainless steel liner connector or elbow to the liner and insert onto the flue collar. Fasten with three screws. Secure the top of the liner to the chimney cap using a liner support and chimney flashing. Cap the top of the chimney liner assembly using an approved rain cap.

In the United States: While it is not required, it is recommended that a chimney liner be installed that is continuous from the insert to the top of the chimney, particularly when the insert is installed in a basement. For this type of connection, use the "In Canada" installation instructions above. If a continuous liner is not installed, a "direct flue connection" must be made. The direct flue connection requires a non-combustible connector that extends from the insert into the chimney flue liner and also that the installed flue cover be sealed below the entry point of the connector to prevent dilution of combustion products in the chimney flue with air from inside the house. Cap the top of the chimney using an approved rain cap.

4.0.2 FACTORY BUILT FIREPLACE

The following installation requirements must be observed when installing solid fuel burning inserts into factory built fireplaces.

- A. The factory built fireplace must be listed per UL 127 or ULC S610.
- B. Clearances to any combustible material surrounding this insert as identified must be followed. These clearance requirements supersede any pre-existing facing material clearances listed for the factory built fireplace.
- C. Installation must include a full height listed chimney liner meeting HT requirements (2100°F) as required in UL 1777 (U.S.) or ULC S635 (Canada). The liner must be securely attached to the insert flue collar and the chimney top.
- D. Means must be provided to prevent room air passage to the chimney cavity of the fireplace. This may be accomplished by sealing the damper area around the chimney liner, or sealing the appliance front.
- E. The air flow within and around the appliance shall not be altered by the installation of the insert (i.e. no louvres or cooling air inlet or outlet ports are blocked), unless specifically tested as such for each factory built fireplace manufacturer and model line. **NOTE: Using a louvered face plate (surround) complies with this requirement.**
- F. Alteration of the appliance in any manner is not permitted with the following exceptions;
 - A. External trim pieces which do not affect the operation of the appliance may be removed providing they can be stored on or within the fireplace for reassembly if the insert is removed.
 - B. The chimney damper may be removed to install the chimney liner.
- G. Circulating air chambers (i.e. in a steel fireplace liner or metal heat circulator) shall not be blocked.
- H. Means must be provided for removal of the insert to clean the chimney flue.
- I. Inserts that project in front of the fireplace must be supplied with appropriate support means.
- J. A permanent metal warning label must be attached to the back of the fireplace stating that the fireplace must be restored to its original condition for safe use without the insert.

80.2A

4.1 LOW CLEARANCE FLUE CONNECTOR (1402)

An optional low clearance flue connector is available to facilitate hook up into a tight fitting fireplace. Consult your local dealer for details.

NOTE: This kit should be used in conjunction with a dripless connector between the flue collar and flex liner.

- 4.1.1 Having ensured that the chimney is thoroughly clean, install the flex liner. Insert a dripless connector into the flue collar. Attach the flex liner to other end of the adapter. Secure using 6 - #8 screws.

- 4.1.2-3 Coil the rope gasket around the insert flue collar sealing the gap between the collar and the insert top. Using 4 - #8 screws, attach the collar flange, squeezing the gasket tightly into place.

- 4.1.4-5 Move the insert into place in the fireplace. Maneuver the insert clips into the two slots located on the insert top by reaching through the insert flue collar from inside the insert.

- 4.1.6 Thread the #10 - 24 screw through the slot located on the insert top and into the threaded hole on the flue connector, allowing the flue connector to be drawn forward into place.

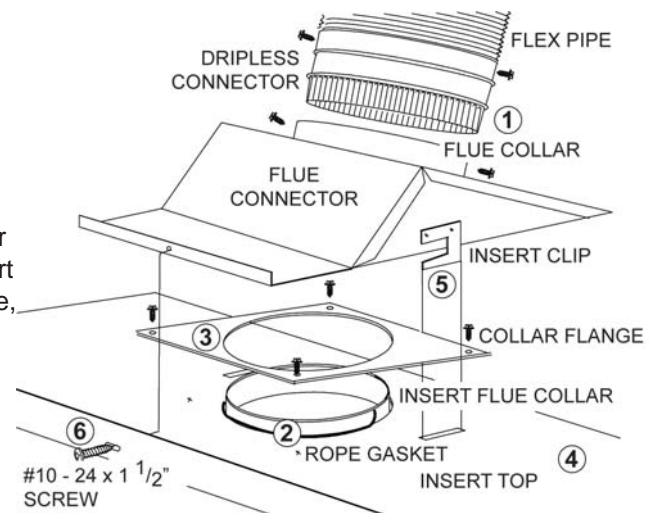

NOTE: Check for a good seal between the insert top and the flue connector (by holding a flashlight up through the insert collar, etc.).

5.0 FINISHING

5.1 BRICKS AND BAFFLES INSTALLATION

! WARNING

OPERATION OF THE APPLIANCE WITHOUT THE BAFFLES CAN RESULT IN EXCESSIVE TEMPERATURES THAT COULD DAMAGE THE APPLIANCE, CHIMNEY AND THE SURROUNDING ENCLOSURE.

- 5.1.1** Install (1101) four (A) bricks and one (C) brick or (1402) six (A) bricks along both sides of the appliance. Before installing the back bricks, loosen the screw holding the retainer and ensure that it has been moved forward. Install the four (A) bricks and two (D) bricks along the back wall by pivoting the bricks up under the brick retainer. Retighten the screw. **NOTE: Center (D) bricks have been notched.**
- 5.1.2** Carefully pivot fibre baffle (G) and (H) up onto the top of the side brick. Slide it over onto the flange of the manifold. Ensure that the top baffles are pushed all the way to the rear of the firebox, leaving a minimum of a 1" gap along the front. This will allow the flue gases to escape the firebox.
- 5.1.3** Install the bottom (1101) four (A) bricks and two (B) bricks or (1402) six (A) bricks and two (B) bricks, working from the back of the appliance forward.
- 5.1.4** Install the two (B) bricks, one (E) brick and one (F) brick along the front as illustrated.

NOTE: Do not operate if baffle and manifold shield are not in position.

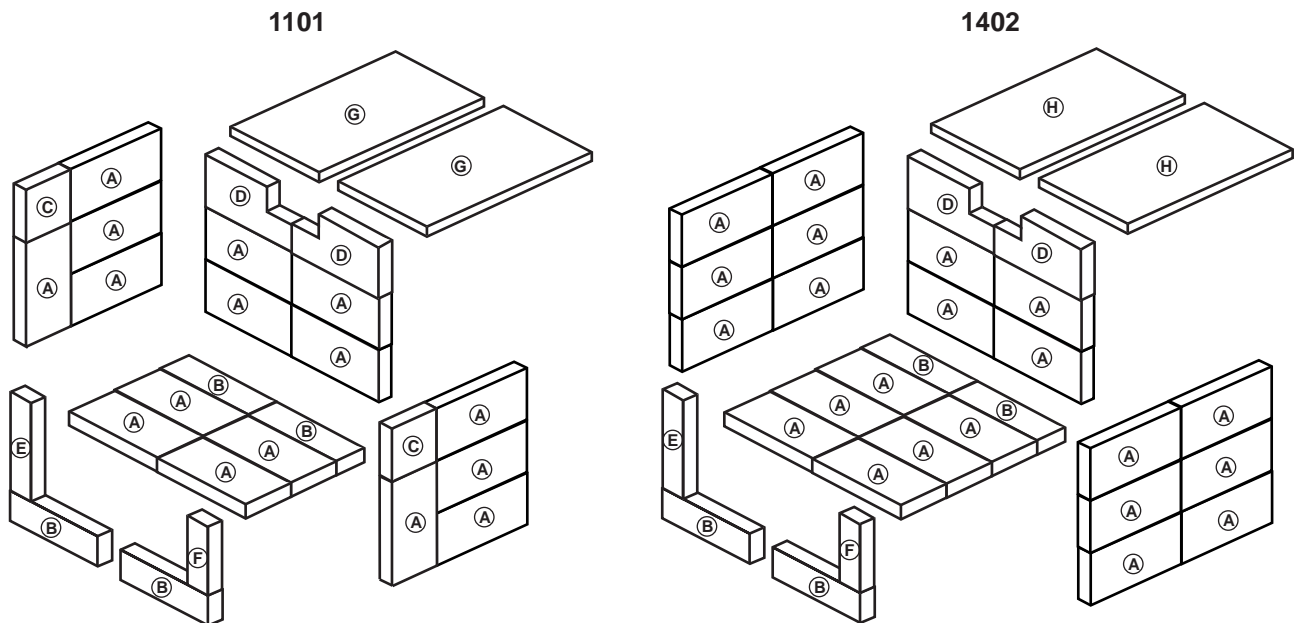

5.2 DOOR REMOVAL / INSTALLATION

 WARNING
BURNING YOUR APPLIANCE WITH THE DOORS OPEN OR AJAR CREATES A FIRE HAZARD THAT MAY RESULT IN A HOUSE AND OR CHIMNEY FIRE.
DO NOT STRIKE OR SLAM DOOR.
NEVER REMOVE THE DOOR WHEN THE APPLIANCE IS HOT.

Hang the door using the hinge pins supplied.

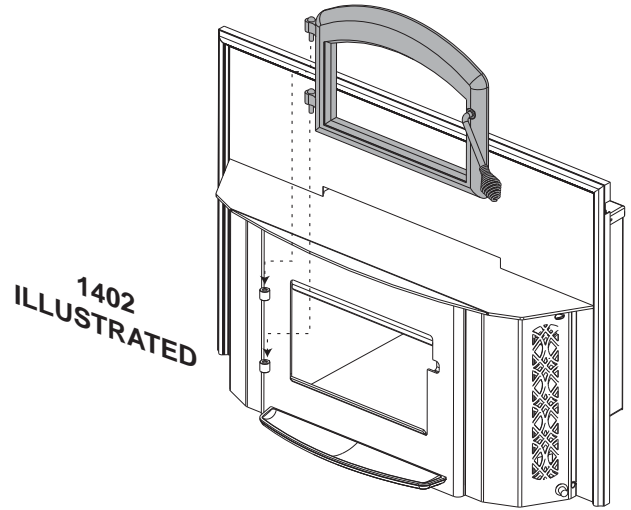

5.3 DOOR HANDLE INSTALLATION

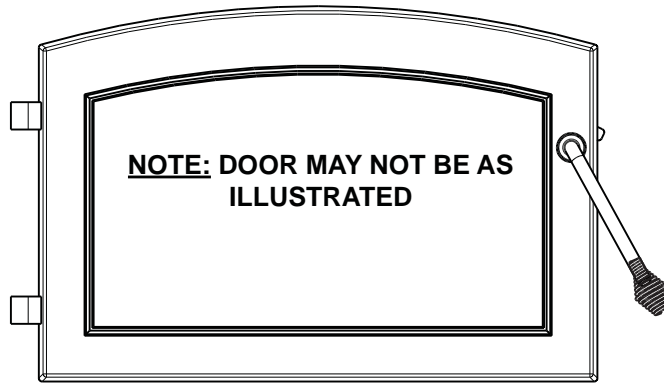

FRONT VIEW

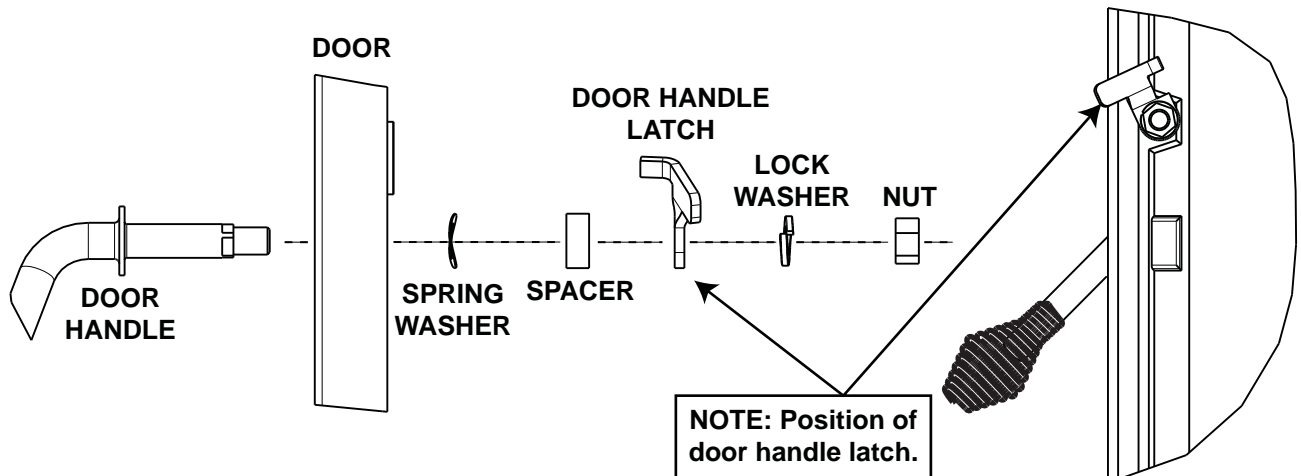

Twist the large wire handle over the end of the handle rod. Twist the smaller wire handle over the end of the air damper rod below the door.

5.4 FLASHING INSTALLATION

The top flashing has been shipped flat. To install the flashing, rest the bottom against the top of the appliance and secure using the tabs as illustrated below.

Slide the trim over the flashing.

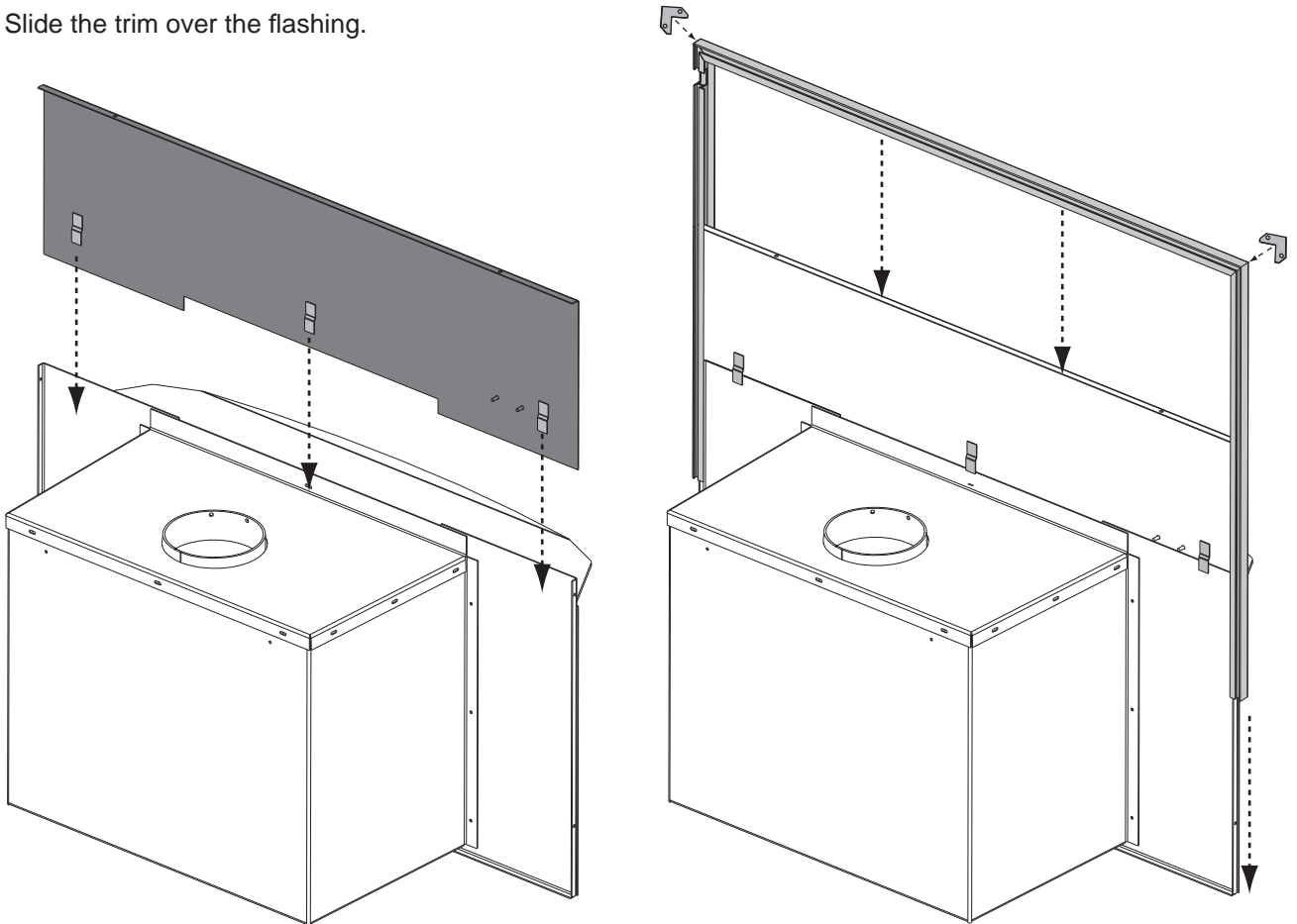

1402 illustrated. For 1101 flashing instructions please refer to the leaflet provided within the flashing kit.

6.0 OPERATION

 WARNING
ALWAYS OPERATE THIS APPLIANCE WITH THE DOOR CLOSED AND LATCHED EXCEPT DURING START UP AND RE-FUELING OR WHEN USING THE SPARK SCREEN. ALWAYS WEAR GLOVES TO PREVENT INJURY. DO NOT LEAVE THE FIRE UNATTENDED WHEN THE DOOR IS UNLATCHED OR WHEN USING A SPARK SCREEN AS UNSTABLE WOOD COULD FALL OUT OF THE FIRE CHAMBER CREATING A FIRE HAZARD TO YOUR HOME.
NEVER LEAVE CHILDREN UNATTENDED WHEN THERE IS A FIRE BURNING IN THE APPLIANCE.
NEVER USE GASOLINE, GASOLINE-TYPE LANTERN FUEL, KEROSENE, CHARCOAL LIGHTER FLUID, OR SIMILAR LIQUIDS TO START OR 'FRESHEN UP' A FIRE IN THIS APPLIANCE. KEEP ALL SUCH LIQUIDS WELL AWAY FROM THE APPLIANCE WHILE IT IS IN USE.
OBJECTS PLACED IN FRONT OF THE APPLIANCE SHOULD BE KEPT A MINIMUM OF 48" FROM THE FRONT FACE.
ANY MODIFICATION OF THE APPLIANCE THAT HAS NOT BEEN APPROVED IN WRITING BY THE TESTING AUTHORITY IS CONSIDERED BREACHING CSA B365 (CANADA) AND ANSI NFPA 211 (USA).
OPEN AIR CONTROL (AND DAMPER WHEN FITTED) BEFORE OPENING FIRING DOOR.
HOT WHILE IN OPERATION, KEEP CHILDREN, CLOTHING AND FURNITURE AWAY. CONTACT MAY CAUSE SKIN BURNS. WEAR GLOVES TO OPERATE YOUR APPLIANCE.
NEVER OPERATE THE STOVE WITH THE GRATE COVER REMOVED.

Your Napoleon EPA listed product is designed with the most advanced technology. The appliance is extremely airtight. It has an exclusive direct outside air supply (optional kit), a safety feature designed to prevent spillage, and to keep your house free of carbon monoxide, in case of a down drafting chimney or an internal negative pressure.

The first fire(s) in your appliance will be difficult to get going and keep going with little amount of heat being generated. This is a result of the moisture being driven out of the fire brick. Allow 30 to 40 hours of hot fires (temperatures in excess of 500°F - 600°F) before your appliance will perform normally. During the break-in period (the first 2 or 3 fires) create only small, hot fires using kindling; this will allow the firebrick to cure. Do not be alarmed if small hairline cracks develop in the firebrick. This is a normal occurrence and does not pose a safety hazard. The paint may also smell a little for the first few fires as it cures and you may wish to open a door or window to alleviate the smell.

To start, a brisk fire is required. Place loosely crumpled paper on the floor of the appliance and cover with dry kindling. Open the draft control fully by pulling the lever forward. Light the paper and leave the door slightly ajar (one inch) until all kindling is burning. To maintain a brisk fire, a hot coal bed must be established and maintained.

Slowly add larger wood (2x4 size pieces). Lay the pieces lengthwise from side to side in the hot coal bed with a shallow trench between, so that the primary air can flow directly into this trench and ignite the fuel above. When the fire seems to be at its peak, medium sized logs may be added. Once these logs have caught fire, carefully close the door. (Closing the door too quickly after refuelling will reduce the firebox temperature and result in an unsatisfactory burn.) Remember it is more efficient to burn medium sized wood, briskly, and refuel frequently than to load the appliance with large logs that result in a smouldering, inefficient fire and dirty glass. As soon as the door is closed, you will observe a change in the flame pattern. The flames will get smaller and lazier because less oxygen is getting into the combustion chamber. The flames, however, are more efficient. The flames will remain lazy but become larger again as soon as the firebricks have been heated thoroughly and the chimney becomes heated and provides a good draft. At this point, the roaring fire that you see when the door is opened is wastefully drawing heated room air up the chimney -- certainly not desirable. Always operate with the door fully closed once the medium sized logs have caught fire.

You can now add larger pieces of wood and operate the appliance normally. Once the appliance is entirely hot, it will burn very efficiently with little smoke from the chimney. There will be a bed of orange coals in the firebox and secondary flames flickering just below the top firebrick. You can safely fill the firebox with wood to the top of the door and will get best burns if you keep the appliance pipe temperatures between 250 degrees Fahrenheit (120 degrees Celsius) and 450 degrees Fahrenheit (270 degrees Celsius). A surface thermometer will help regulate this.

Without a appliance thermometer, you are working blindly and have no idea of how the appliance is operating! An appliance thermometer offers a guide to performance and should be located 14" above the flue collar. Install the thermometer according to manufacturers instructions.

Can't get the fire going?

Use more kindling and paper. Assuming the chimney and vent are sized correctly and there is sufficient combustion air, the lack of sufficiently dry quantities of small kindling is the problem. Thumb size is a good gauge for small kindling diameter.

Can't get heat out of the appliance?

One of two things may have happened. The appliance door may have been closed prematurely and the appliance itself has not reached optimum temperature. Reopen the door and/or draft control to re-establish a brisk fire. The other problem may have been wet wood. The typical symptom is sizzling wood and moisture being driven from the wood.

6.1 BLOWER

 WARNING
RISK OF FIRE AND ELECTRICAL SHOCK.
TURN OFF THE ELECTRICAL POWER BEFORE SERVICING THIS APPLIANCE.
USE ONLY WOLF STEEL APPROVED OPTIONAL ACCESSORIES AND REPLACEMENT PARTS WITH THIS APPLIANCE. USING NON-LISTED ACCESSORIES (BLOWERS, DOORS, LOUVRES, TRIMS, ETC.) COULD RESULT IN A SAFETY HAZARD AND WILL VOID THE WARRANTY AND CERTIFICATION.
ENSURE THAT THE BLOWER'S POWER CORD IS NOT IN CONTACT WITH ANY SURFACE OF THE APPLIANCE TO PREVENT ELECTRICAL SHOCK OR FIRE DAMAGE. DO NOT RUN THE POWER CORD BENEATH THE APPLIANCE.

Drywall dust will penetrate into the blower bearings, causing irreparable damage. Care must be taken to prevent drywall dust from coming into contact with the blower or its compartment. Any damage resulting from this condition is not covered by the warranty policy. Use of the blower increases the output of heat.

The 1402 inserts comes equipped with two blowers, while the 1101 has one blower. These blowers are thermally activated. Depending on the intensity of the fire, the blowers will start 15-30 minutes after lighting. The heat sensor for the 1402 is located on the right hand side of the unit and the 1101 has a heat sensor located at the back on the blower access door. When first starting the fire, the sensor may be impeded by a large log or an unevenly burning fire, causing the blowers to cycle on and off. To control this, either build your fire up evenly or turn down the blowers until the right side of the firebox is hot.

6.2 AIR CONTROL

Draft is the force which moves air from the firebox up through the chimney. The amount of draft in your chimney depends on the length and diameter of chimney, local geography, nearby obstructions and other factors including the amount of heat generated by the fire which can be measured by an appliance thermometer.

Adjusting the air control regulates the temperature. The draft can be adjusted from a low burn rate with the handle in fully, to a fast burn rate with the handle fully out.

Inadequate draft may cause back-puffing into the room through the appliance and chimney connector points and may cause plugging of the chimney. Too much draft may cause an excessive temperature in the appliance, glowing red appliance parts or chimney connectors or an uncontrollable burn which can lead to a chimney fire or permanent damage to the appliance.

Do not operate your appliance for longer than 30 minutes with the draft control on "HIGH" (fully open).

6.3 FIRE EXTINGUISHERS / SMOKE DETECTORS

All homes with a solid fuel burning appliance should have at least one fire extinguisher in a central location, known to all, and at least one smoke detector in the room containing the appliance. If it sounds an alarm, correct the cause but do not de-activate or relocate the smoke detector.

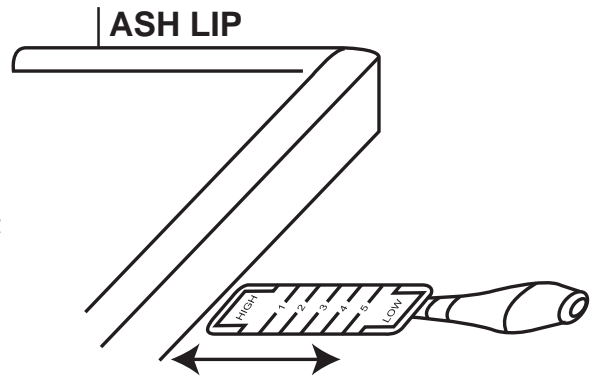

6.4 FUEL

! WARNING
THIS APPLIANCE IS DESIGNED TO BURN NATURAL WOOD ONLY. DO NOT BURN TREATED WOOD, COAL, CHARCOAL, COLOURED PAPER, CARDBOARD, SOLVENTS OR GARBAGE. THIS APPLIANCE HAS NOT BEEN TESTED WITH AN UNVENTED GAS LOG SET. TO REDUCE RISK OF FIRE OR INJURY, DO NOT INSTALL AN UNVENTED GAS LOG SET INTO THE APPLIANCE.
HIGHER EFFICIENCIES AND LOWER EMISSIONS GENERALLY RESULT WHEN BURNING AIR DRIED SEASONED HARDWOODS, AS COMPARED TO SOFTWOODS OR TOO GREEN OR FRESHLY CUT HARDWOODS.
BURNING WET UNSEASONED WOOD CAN CAUSE EXCESSIVE CREOSOTE ACCUMULATION. WHEN IGNITED IT CAN CAUSE A CHIMNEY FIRE THAT MAY RESULT IN A SERIOUS HOUSE FIRE.
DO NOT STORE FUEL WITHIN THE CLEARANCE TO COMBUSTIBLES, OR IN THE SPACE REQUIRED FOR RE-FUELING AND ASH REMOVAL.
BURNING WET, UNSEASONED WOOD CAN CAUSE EXCESSIVE CREOSOTE ACCUMULATION. WHEN IGNITED IT CAN CAUSE A CHIMNEY FIRE THAT MAY RESULT IN A SERIOUS HOUSE FIRE.

When loading the appliance, ensure that the upper fibre baffles are not forced out of position. For maximum efficiency, when the appliance is thoroughly hot, load it fully to the top of the door opening and burn at a medium low setting. The whiteness of the bricks and the cleanliness of the glass are good indicators of your operating efficiency. Not enough heat is produced when only a few pieces of wood are burned or the wood may not burn completely.

Fuel for the appliance must not be stored closer than the required clearances to combustibles (heat sensitive material). **NEVER STORE WOOD IN THE ASH PAN COMPARTMENT (if applicable).**

NOTE: When loading the appliance, ensure to keep fuel back from the glass. If coals are to accumulate on the front lip, there is a chance they will fall out when the door is opened.

Burn only dry, clean unpainted wood that has been seasoned. It produces more heat and less soot or creosote. Freshly cut wood contains about 50% moisture while after proper seasoning only about 20% of the water remains. As wood is burned, this water boils off consuming energy that should be used in heating. The wetter the wood, the less heat is given off and the more creosote is produced. Dry firewood has cracks in the end of the grain.

Both hardwood and softwood burn equally well in this appliance but hardwood is denser, will weigh more per cord and burn a little slower and longer.

Firewood should be split, stacked in a manner that air can get to all parts of it and covered in early spring to be ready for burning that fall. Dry firewood has cracks in the end grain.

Cut the wood so that it will fit horizontally, front to back, making for easier loading and less of a likelihood that the wood will roll onto the glass.

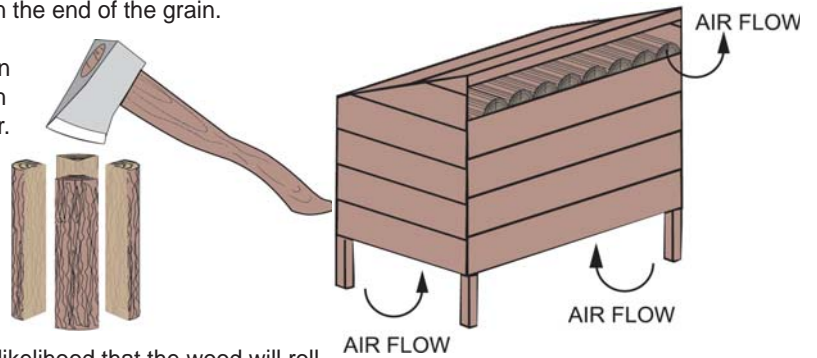

DO'S

- Build a hot fire.
- Use only dry wood.
- Several pieces of medium sized wood are better than a few big pieces.
- Clean chimney regularly.
- Refuel frequently using medium sized wood.
- "Fine Tune" the air settings for optimum performance.

DONT'S

- Take ash out immediately. Let it accumulate to a depth of at least one inch. A good ash layer provides for a longer lasting and better burning fire.
- Burn wet wood.
- Close the door too soon or damper down too quickly.
- Burn one large log rather than two or three smaller, more reasonably sized logs.
- Burn at continually "low setting", if glass door is constantly blackened. This means the firebox temperature is too low.

87.1A

6.5 LIGHTING A FIRE

6.5.1 FLASH FIRE

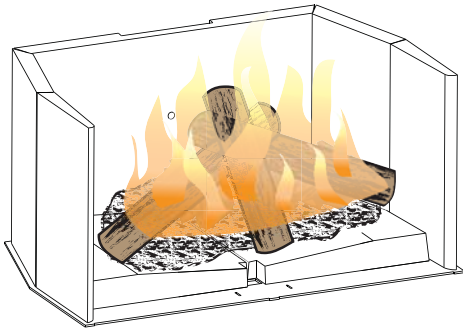

A flash fire is a small fire burned quickly when you don't need much heat. After your kindling has "caught", load at least 3 pieces of wood, stacked loosely. Burn with the draft control fully open or closed only slightly.

93.1

6.5.2 EXTENDED FIRE

Load your larger pieces of wood compactly, packed close enough to prevent the flames from penetrating it completely. After approximately 30 minutes, depending on the size of the load, close the draft control completely making sure that the fire is not extinguished.

DO NOT OVERFIRE THE APPLIANCE!

Overfiring can occur by:

- A. Burning large amounts of smaller wood pieces such as furniture scraps, skids or treated wood;
- B. Vigorously burning large loads of wood with the draft control on "HIGH" (fully open) for long periods of time (one or two hours).
- C. Operating the appliance with the ash dump door blocked open or a poor gasket seal on the main door.

82.1

6.6 SMOKING

A properly installed appliance should not smoke. If yours does, check the following:

- Has the chimney had time to get hot?
 - Is the smoke passage blocked anywhere in the appliance, chimney connector or chimney?
 - Is the room too airtight and the air intake not connected to the outside? Try with a window partly open.
 - Is the smoke flow impeded by too long a horizontal pipe or too many bends?
 - Is it a weak draft perhaps caused by a leaky chimney, a cold outside chimney, too large a diameter of a chimney, too short a chimney, or a chimney too close to trees or a higher roof?
-
- 83.1
- Has a direct flue connection been used rather than a chimney liner continuous from cap to appliance flue collar.

7.0 MAINTENANCE

! WARNING
TURN OFF THE POWER BEFORE SERVICING THE APPLIANCE.
APPLIANCE MAY BE HOT, DO NOT SERVICE UNTIL APPLIANCE HAS COOLED.
DO NOT USE ABRASIVE CLEANERS.

Check your chimney and chimney connector for creosote and soot buildup weekly until a safe frequency for cleaning is established.

If accumulation is excessive, disconnect the appliance and clean both the chimney and the appliance. You may want to call a professional chimney sweep to clean them. Both have to be cleaned at least once a year or as often as necessary.

Remove fibre baffles and clean above them once a year. Replace any broken bricks.

7.1 ASH REMOVAL PROCEDURES

! WARNING
IMPROPER DISPOSAL OF ASHES RESULT IN FIRES. DO NOT DISCARD ASHES IN CARDBOARD BOXES, DUMP IN BACK YARDS, OR STORE IN GARAGES.
IF USING A VACUUM TO CLEAN UP ASHES, BE SURE THE ASHES ARE ENTIRELY COOLED. USING A VACUUM TO CLEAN UP WARM ASHES COULD CAUSE A FIRE INSIDE THE VACUUM.
NEVER OPERATE YOUR APPLIANCE WITH THE ASH PLUG (IF APPLICABLE) REMOVED.
FAILURE TO ACHIEVE A GOOD SEAL BETWEEN THE ASH OPENING, ASH PLUG OR ASH WELL DOOR WILL RESULT IN AN OVER FIRE CONDITION THAT COULD CAUSE DAMAGE TO THE APPLIANCE.

Allow the ashes in your firebox to accumulate to a depth of two or three inches; they tend to burn themselves up. When the fire has burned down and cooled, remove any excess ashes but leave an ash bed approximately 1 inch deep on the firebox bottom to help maintain a hot charcoal bed.

Shovel some ashes out through the door into a metal container with a tight fitting lid. Leave an ash bed approximately 1 inch deep on the firebox bottom to help maintain a hot charcoal bed. Keep the closed container on a noncombustible floor or ground, well away from all combustible materials. The ashes should be retained in the closed container until all cinders have thoroughly cooled. Cold wood ashes can be used on the garden or in the compost.

7.2 CREOSOTE FORMATION AND REMOVAL

When wood is burned slowly, it produces tar and other organic vapours which combine with expelled moisture to form creosote. These vapours condense in the relatively cooler chimney flue of a slow burning fire and when ignited, make an extremely hot fire. So, the smoke pipe/chimney liner and chimney should be inspected monthly during the heating season to determine if a buildup has occurred. If creosote has accumulated it should be removed to reduce the risk of a chimney fire.

7.3 RUNAWAY OR CHIMNEY FIRE



A CHIMNEY FIRE CAN PERMANENTLY DAMAGE YOUR CHIMNEY SYSTEM. THIS DAMAGE CAN ONLY BE REPAIRED BY REPLACING THE DAMAGED COMPONENT PARTS. CHIMNEY FIRES ARE NOT COVERED BY THE LIFETIME LIMITED WARRANTY.

CAUSES:

- Using incorrect fuel, or small fuel pieces which would normally be used as kindling.
- Leaving the door ajar too long and creating extreme temperatures as the air rushes in the open door.
- Improperly installed or worn gaskets.
- Creosote build up in chimney.

SOLUTIONS:

- Do not burn treated or processed wood, coal, charcoal, coloured paper or cardboard.
- Be careful not to overfire the appliance by leaving the door open too long after the initial start-up. A thermometer on the chimney connector and/or appliance top helps.
- Replace worn, dried out (inflexible) gaskets.
- Have chimney regularly cleaned.

IN CASE OF A CHIMNEY FIRE:

- Have a well understood plan for evacuation and a place outside for everyone to meet. Prepare to evacuate to ensure everyone's safety.
- Close air control on appliance.
- Call local fire department. Have a fire extinguisher handy. Contact local authorities for further information on how to handle a chimney fire.
- After the chimney fire is out, clean and inspect the chimney or chimney liner for stress and cracks prior to lighting another fire. Also check combustibles around the chimney and the roof.

 85.2

7.4 CHIMNEY CLEANING

Both the chimney and the appliance must be inspected and cleaned if necessary at least once a year. For serious wood burners, chimney cleaning must be done as needed to avoid chimney fires; the venting systems for controlled combustion appliances may need cleaning as often as once a month. These rates, however, depend on the burning habits of the individual operating the appliance. For example, it is possible to clog a solid fuel appliance chimney in a few days if slow, smoldering fires are burned and the chimney is cold.

NOTE: Appliances burned consistently without hot fires may result in significant creosote accumulations in the chimney.

Certain items and considerations are important in chimney cleaning:

- Proper tools should be used, including a brush specifically designed for chimney cleaning.
- The chimney connector and dampers as well as the chimney should be cleaned.
- The appliance's firebox and baffle system should be cleaned if needed.
- The chimney should be inspected and repairs made if needed, preferably by a qualified chimney sweep or mason.

 86 1

7.5 GLASS REPLACEMENT

! WARNING
DO NOT USE SUBSTITUTE MATERIALS.
GLASS MAY BE HOT, DO NOT TOUCH GLASS UNTIL COOLED.
CARE MUST BE TAKEN WHEN REMOVING AND DISPOSING OF ANY BROKEN DOOR GLASS OR DAMAGED COMPONENTS. BE SURE TO VACUUM UP ANY BROKEN GLASS FROM INSIDE THE APPLIANCE BEFORE OPERATION.
DO NOT STRIKE, SLAM OR SCRATCH GLASS. DO NOT OPERATE APPLIANCE WITH GLASS REMOVED, CRACKED, BROKEN OR SCRATCHED.

56.2

- A. When the appliance is cool, open the door and place the door frame down careful not to scratch the paint.
- B. Remove the screws and brackets holding the glass in place. Remove all broken glass.
- C. Wrap the edges of the new glass with a U-shaped strip of fiberglass gasket, covering 1/4" on each side.
- D. Place the glass with the fiberglass gasket in position and replace the brackets and screws. When finished, you should be able to move the glass slightly, horizontally and vertically.

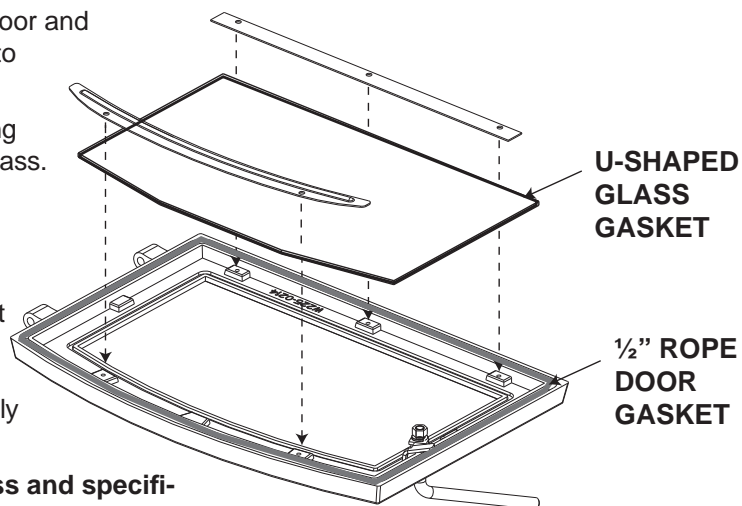

NOTE: For replacement glass, size, thickness and specifications see “REPLACEMENTS” section.

7.6 GASKET REPLACEMENT

At the end of each burning season inspect the shield and gasket below the manifold for warping or deterioration. Replace if necessary. Both are held to the manifold with machine screws. The shield and the 1/8" fibre cloth gasket are available from your Wolf Steel Ltd. dealer. At this time also check that the door gasket is not worn or loose. Replace with 1/2" high density fibreglass rope if necessary.

The airwash gasket and shield above the door should also be inspected and replaced if deteriorated

NOTE: Do not operate appliance if gasket, manifold shield or fibre baffle is deteriorated or missing.

7.7 CARE OF GLASS

If the glass is not kept clean permanent discolouration and / or blemishes may result. Normally a hot fire will clean the glass. The most common reasons for dirty glass include: not using sufficient fuel to get the appliance thoroughly hot, using green or wet wood, closing the draft so far that there is insufficient air for complete combustion.

If it is necessary to clean the glass, buff lightly with a clean dry cloth and non-abrasive cleaner.



DO NOT CLEAN GLASS WHEN HOT! Clean the glass after the first 10 hours of operation with a recommended appliance glass cleaner. Thereafter clean as required.

The glass is very strong but do not let burning fuel rest or fall against it and always close the door gently. **NEVER FORCE IT SHUT!**

If the glass should ever crack or break while the fire is burning, do not open the door until the fire is out and do not operate the appliance again until the glass has been replaced, available from your Authorized dealer. **DO NOT SUBSTITUTE MATERIALS.**

5.3

7.8 CARE OF PLATED PARTS

If the appliance is equipped with plated parts, you must clean fingerprints or other marks from the plated surfaces before operating the appliance for the first time. Use a glass cleaner or vinegar and towel to clean. If not cleaned properly before operating for the first time, the marks can cause permanent blemishes on the plating. After the plating is cured, the fingerprints and oils will not affect the finish and little maintenance is required, just wipe clean as needed. Prolonged high temperature burning with the door ajar may cause discolouration on plated parts.

NOTE: The protective wrap on plated parts is best removed when the assembly is at room temperature but this can be improved if the assembly is warmed, using a hair dryer or similar heat source.

6.1

7.9 BLOWER SERVICE OR REPLACEMENT (1101)

- A. Turn off all electrical power to the appliance. Remove the glass door and set aside in a safe place.
- B. Remove the top right side bricks from inside the firebox, 4-#7's and 2-#2's. Then remove the rest of the side and back bricks from the right side of the appliance. It is not necessary to remove the bottom bricks.
- C. The access panel can be removed by taking out the 8 #10 self tapping screws. A 5/16" nut driver will be required to complete this job. Unplug wires from the thermal switch on the panel.
- D. Remove the securing wing nut from the blower mounting bracket, slide the bracket to the right and rotate the left side of the assembly out of the cavity to clear the blower motor. Disconnect the two wires from the blower motor. Remove the ground wire from the blower mounting bracket, then the assembly can be taken out of the rear cavity through the access door opening.
- E. Remove the 3 screws that hold the blower to the mounting bracket. Service or replace the blower as required.
- F. Reinstall the blower assembly making sure the blower bracket is seated under the securing tab. Reattach the wire connectors.
- G. Replace the gasket on the access door. To replace the access panel, reverse Step C.
- H. Replace the bricks into the firebox. Reinstall the door.

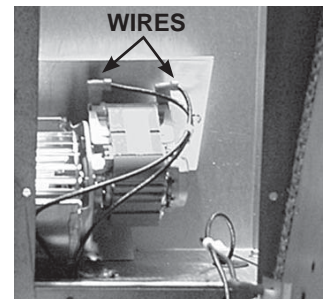
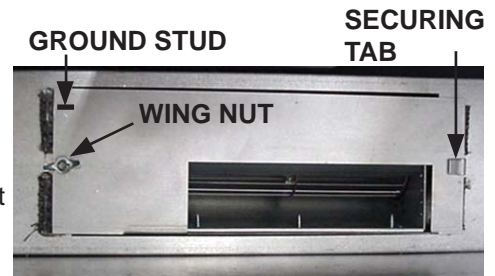
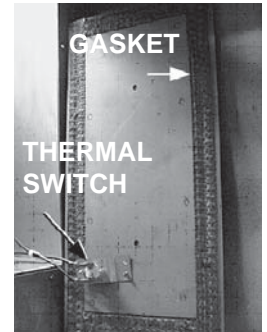

7.10 BLOWER SERVICE OR REPLACEMENT (1402)

- A. Turn off all electrical power to the insert. Remove the glass door and set aside in a safe place.
- B. Remove the two screws from the outer edge of the side panel(s).
- C. Push the side panel toward the door and pull away from the insert, releasing the panel from the keyed slot.
- D. Service or replace the blower(s) as required.
- E. Re-install the side panel(s) by reversing the procedure.

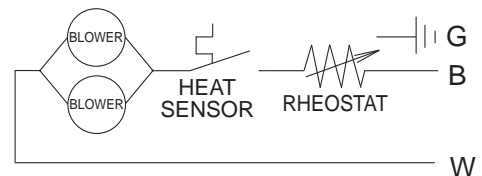
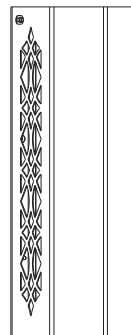

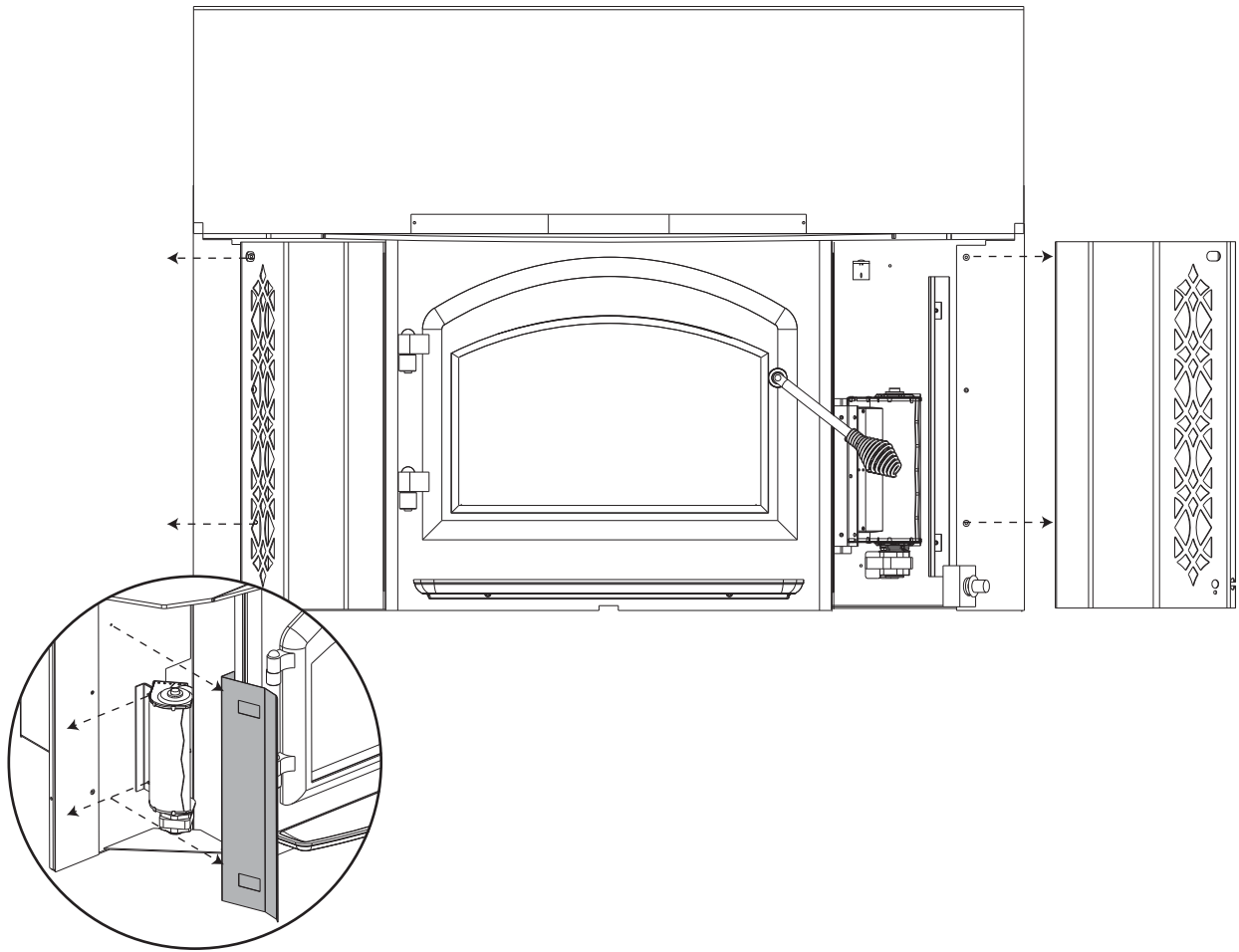

LEFT BLOWER ACCESS

8.0 REPLACEMENTS

Contact your dealer or the factory for questions concerning prices and policies on replacement parts. Normally all parts can be ordered through your Authorized dealer / distributor.

FOR WARRANTY REPLACEMENT PARTS, A PHOTOCOPY OF THE ORIGINAL INVOICE WILL BE REQUIRED TO HONOUR THE CLAIM.

When ordering replacement parts always give the following information:

- Model & Serial Number of appliance
- Installation date of appliance
- Part number
- Description of part
- Finish

*** IDENTIFIES ITEMS WHICH ARE NOT ILLUSTRATED. FOR FURTHER INFORMATION, CONTACT YOUR AUTHORIZED DEALER.**



41.1

COMMON COMPONENTS		
REF NO.	PART NO.	DESCRIPTION
1a*	W325-0042	SPRING HANDLE - SMALL BLACK
1b	W325-0043	SPRING HANDLE - LARGE BLACK
2	W090-0001	BRICK - # 1
3	W090-0002	BRICK - # 2
4	W090-0004	BRICK - # 4 LEFT
5	W090-0005	BRICK - # 4 RIGHT
6	W090-0018	BRICK - # 8
7	W090-0019	BRICK - # 9
8	W135-0238	ASH LIP
9*	W010-0347	AIRWASH GASKET & SHIELD
10*	W570-0007	SCREWS FOR MANIFOLD & SHIELD
11	GZ552	REPLACEMENT FAN
12	W690-0002	THERMAL SWITCH
13	KB-36	VARIABLE SPEED CONTROL C/W KNOB
14	W010-1071	DOOR GLASS W/ GASKET
15*	W020-0043	DOOR GASKET
16*	W020-0050	GLASS GASKET
1101 COMPONENTS		
REF NO.	PART NO.	DESCRIPTION
17	W090-0003	BRICK - # 3
18	W018-0077	#10 FIBRE BAFFLE
19*	EP-11MS	MANIFOLD GASKET & SHIELD
20*	W580-0006	COMPLETE BRICK SET
1402 COMPONENTS		
REF NO.	PART NO.	DESCRIPTION
21*	W018-0078	#11 FIBRE BAFFLE
22*	EP-14MS	MANIFOLD GASKET & SHIELD
23*	W580-0005	COMPLETE BRICK SET

COMMON ACCESSORIES

REF NO.	PART NO.	DESCRIPTION
24	H222-G	GOLD PLATED DOOR
24	H222	BLACK DOOR
24	H222-SS	BRUSHED STAINLESS STEEL DOOR - STANDARD ARCH
25	H222-W	BLACK DOOR - EARLY AMERICAN
25	H222-GW	GOLD DOOR - EARLY AMERICAN
25	H222-SSW	BRUSHED STAINLESS STEEL DOOR - EARLY AMERICAN
26	CISK**	CAST IRON SURROUND KIT - PAINTED BLACK
27	CISK**A	CAST IRON SURROUND KIT - ENAMEL PORCELAIN

1101 COMPONENTS

REF NO.	PART NO.	DESCRIPTION
28	AK-1	ADAPTER KIT FOR CISK
29	EI-900K10	10" FLASHING KIT C/W BULL NOSE TRIM

1402 COMPONENTS

REF NO.	PART NO.	DESCRIPTION
30*	W470-0002	ENAMEL TOUCH UP & BRUSH (SPECIFY COLOUR)
31*	EPA335KT	LOW CLEARANCE FLUE CONNECTOR
32	AK-2	ADAPTER KIT FOR CISK-A

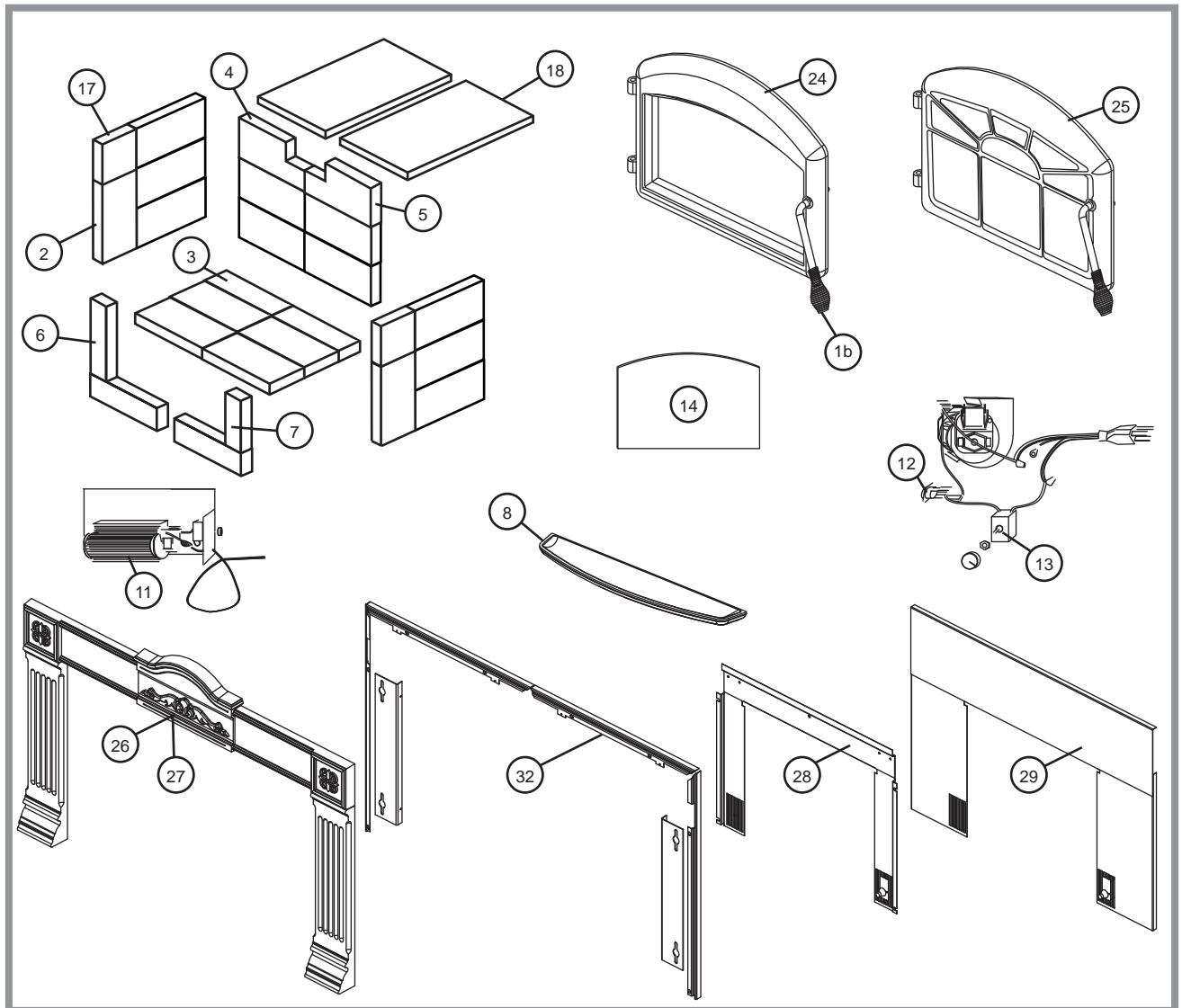

9.0 TROUBLE SHOOTING

 WARNING
TURN OFF THE ELECTRICAL POWER BEFORE SERVICING THE APPLIANCE.
APPLIANCE MAY BE HOT, DO NOT SERVICE UNTIL APPLIANCE HAS COOLED.
DO NOT USE ABRASIVE CLEANERS.
WHEN CHECKING CONNECTIONS, INSTALLING JUMPER WIRES (FOR TEST PURPOSES ONLY) OR REPLACING COMPONENTS, UNPLUG HEATER FROM THE RECEPTACLE TO PREVENT ELECTRICAL SHOCK OR DAMAGE TO THE COMPONENT.

PROBLEM	SOLUTION
Can't get the fire started.	<ul style="list-style-type: none"> - Not enough kindling / paper? Add more. - Not enough air? Ensure air control is fully open. - Cold air blockage? Burn a piece of paper to establish a draft. - Use dry seasoned wood. - Flue blockage? Inspect chimney.
Smokes when door is open.	<ul style="list-style-type: none"> - Cold air blockage? Burn a piece of paper to establish a draft. - Insufficient draft? Add more pipe. - Let air stabilize before opening door. - Ensure baffles are positioned correctly. - Negative pressure? Open a window near the appliance.
Appliance emits odour.	<ul style="list-style-type: none"> - Paint curing. See "GENERAL INSTRUCTIONS" section.
Stove doesn't burnt hot enough.	<ul style="list-style-type: none"> - Wood is too wet. - Insufficient draft? Add more pipe. - Not enough air? Ensure air control is fully open.
Wood burns too fast.	<ul style="list-style-type: none"> - Air control may need to be adjusted down. - Check to see ash plug is properly seated (if equipped). - Check door gasket for adequate seal. - Wood may be extremely dry.
Dirty glass.	<ul style="list-style-type: none"> - Air control may be closed too far. - Burn hotter, smaller fires. - Use well seasoned wood.
Blower does not run.	<ul style="list-style-type: none"> - Appliance may not be up to temperature. - Ensure blower has power.

42.14A

10.0 WARRANTY

NAPOLEON® products are manufactured under the strict Standard of the world recognized ISO 9001 : 2008 Quality Assurance Certificate.

NAPOLEON® products are designed with superior components and materials, assembled by trained craftsmen who take great pride in their work. The complete appliance is again thoroughly inspected by a qualified technician before packaging to ensure that you, the customer, receives the quality product that you expect from NAPOLEON®.

NAPOLEON® WOOD APPLIANCE PRESIDENT'S LIFETIME LIMITED WARRANTY

The following materials and workmanship in your new NAPOLEON® wood appliance are warranted against defects for as long as you own the appliance. This covers: combustion chamber, heat exchanger, ceramic glass (thermal breakage only), gold plated parts against tarnishing, porcelainized enameled components, aluminum extrusion trims, vortex baffles, ash drawer and iron castings.

Electrical (110V) components and wearable parts such as blowers, thermal switch, switches, wiring, firebrick, stainless steel baffle retainer, secondary air tubes, and gasketing are covered and NAPOLEON® will provide replacement parts free of charge during the first year of the limited warranty. *

Labour related to warranty repair is covered free of charge during the first year. Repair work, however, requires the prior approval of an authorized company official. Labour costs to the account of NAPOLEON® are based on a predetermined rate schedule and any repair work must be done through an authorized NAPOLEON® dealer.

Parts such as firebricks and baffles should routinely be removed by the operator as part of the regular service and therefore, any warranty replacement of these parts does not qualify for any labour allowances.

* Construction of models vary. Warranty applies only to components included with your specific appliance.

CONDITIONS AND LIMITATIONS

NAPOLEON® warrants its products against manufacturing defects to the original purchaser only. Registering your warranty is not necessary. Simply provide your proof of purchase along with the model and serial number to make a warranty claim. Provided that the purchase was made through an authorized NAPOLEON® dealer your appliance is subject to the following conditions and limitations:

Warranty coverage begins on the date of original installation.

This factory warranty is non-transferable and may not be extended whatsoever by any of our representatives.

The wood appliance must be installed by an authorized service technician or contractor. Installation must be done in accordance with the installation instructions included with the product and all local and national building and fire codes.

This limited warranty does not cover damages caused by misuse, lack of maintenance, accident, alterations, abuse or neglect and parts installed from other manufacturers will nullify this warranty.

This limited warranty further does not cover any scratches, dents, corrosion or discoloring caused by excessive heat, abrasive and chemical cleaners nor chipping on porcelain enamel parts, nor any venting components used in the installation of the appliance.

This warranty extends to the repair or replacement of warranted parts which are defective in material or workmanship provided that the product has been operated in accordance with the operation instructions and under normal conditions.

After the first year, with respect to the President's Lifetime Limited Warranty, NAPOLEON® may, at its discretion, fully discharge all obligations with respect to this warranty by refunding to the original warranted purchaser the wholesale price of any warranted but defective part(s).

After the first year, NAPOLEON® will not be responsible for installation, labour or any other costs or expenses related to the reinstallation of a warranted part, and such expenses are not covered by this warranty.

Notwithstanding any provisions contained in the President's Lifetime Limited Warranty, NAPOLEON's responsibility under this warranty is defined as above and it shall not in any event extend to any incidental, consequential or indirect damages.

This warranty defines the obligations and liability of NAPOLEON® with respect to the NAPOLEON® wood appliance and any other warranties expressed or implied with respect to this product, its components or accessories are excluded.

NAPOLEON® neither assumes, nor authorizes any third party to assume, on its behalf, any other liabilities with respect to the sale of this product.

NAPOLEON® will not be responsible for: over-firing, downdrafts, spillage caused by environmental conditions such as rooftops, buildings, nearby trees, hills, mountains, inadequate vents or ventilation, excessive venting configurations, insufficient makeup air, or negative air pressures which may or may not be caused by mechanical systems such as exhaust fans, furnaces, clothes dryers, etc.

Any damages to appliance, combustion chamber, heat exchanger, plated trim or other component due to water, weather damage, long periods of dampness, condensation, damaging chemicals or cleaners will not be the responsibility of NAPOLEON®.

NAPOLEON® reserves the right to have its representative inspect any product or part thereof prior to honouring any warranty claim.

All parts replaced under the President's Limited Lifetime Warranty Policy are subject to a single claim.

During the first 10 years NAPOLEON® will replace or repair the defective parts covered by the lifetime warranty at our discretion free of charge. From 10 years to life, NAPOLEON® will provide replacement parts at 50% of the current retail price.

All parts replaced under the warranty will be covered for a period of 90 days from the date of their installation.

The manufacturer may require that defective parts or products be returned or that digital pictures be provided to support the claim. Returned products are to be shipped prepaid to the manufacturer for investigation. If a product is found to be defective, the manufacturer will repair or replace such defect.

Before shipping your appliance or defective components, your dealer must obtain an authorization number. Any merchandise shipped without authorization will be refused and returned to sender.

Shipping costs are not covered under this warranty.

Additional service fees may apply if you are seeking warranty service from a dealer.

Warranty labour allowance is only for the replacement of the warranted part. Travel, diagnostic tests, shipping and other related charges are not covered by this warranty.

ALL SPECIFICATIONS AND DESIGNS ARE SUBJECT TO CHANGE WITHOUT PRIOR NOTICE DUE TO ON-GOING PRODUCT IMPROVEMENTS. NAPOLEON® IS A REGISTERED TRADEMARK OF WOLF STEEL LTD. PATENTS U.S. 5.303.693.801 - CAN. 2.073.411, 2.082.915. © WOLF STEEL LTD.

